

INSTALLATION, OPERATION AND MAINTENANCE MANUAL

9610CXc™



Version: 1.5.2
Revision date: June 28th, 2024

CAL.01.D.9826

Process Insights

New York Manufacturing Offices:

84G Horseblock Rd.
Yaphank, NY 11980
Tel: 631-345-3434

Texas Corporate Headquarters, Sales & Service Offices:

Building 6, 14400 Hollister St.
Suite 800-B
Houston, TX 77066
Tel: 713-947-9591
Fax: 713-947-7549

E-mail: support.hou@process-insights.com

Website: <http://www.process-insights.com>

Copyright © 2021
All rights reserved.

The contents of this publication are presented for informational purposes only. While every effort has been made to ensure this document error-free, it should not be construed as warranties or guarantees, expressed or implied, regarding the product or services described herein or its use or applicability.

Process Insights Corporation reserves the right to revise or to improve the design or specifications of the 9610CXc™ at any time and without notice.

Table of Contents

1. INTRODUCTION	7
1.1. INTRODUCTION	7
1.1.1. Purpose of the analyzer	7
1.2. SPECIFIC CONDITIONS OF USE	7
1.3. THE 9610CXc™ ANALYZER.....	7
1.3.1. Oven with oxygen sensor	8
1.3.2. The sample system (SCS).....	8
1.4. CALIBRATION PROCEDURE	9
1.5. EXTENDED (DUAL) RANGE OPTION	11
1.5.1. Operation.....	11
1.6. SPECIFICATIONS 9610CXc™ WOBBE INDEX ANALYZER.....	11
1.6.1. Analyzer performance.....	11
1.6.2. Utilities	12
1.6.3. Installation.....	13
1.6.4. Connection	13
1.7 X-Purge Option.....	14
1.7.1. Purpose.....	14
1.7.2. Operation of X-purge and component kits.....	15
1.7.2.1 Operation	15
1.7.2.2. Electronic Power Control Unit – EPCU	16
1.7.2.3. User-Interface Controller – UIC.....	16
1.7.2.4. Pneumatic Manifold with I.S. Solenoid	17
1.7.2.5. Purge Timing	17
1.7.2.6. Fixed Purge Time.....	18
1.7.2.7. Dynamic Purge Time	18
1.7.2.8. Purging Modes.....	18
1.7.2.9. Inputs	19
1.7.2.10. Outputs	19
1.7.2.11. EPV-6000 I.S. Relief Vent.....	20
1.8 Z-Purge Option.....	21

1.8.1 Purpose.....	21
1.8.2. Operation.....	22
1.9 Flow alarm	22
2.0 System maintenance.....	23
2. INSTALLATION.....	25
2.1. GENERAL.....	25
2.2. STORAGE.....	25
2.3. PLACEMENT.....	25
2.3.1. General	25
2.3.2. 9610CXc™ in general purpose execution.....	26
2.4. MECHANICAL CONNECTIONS.....	26
2.4.1. General.....	26
2.4.2. Sample supply.....	28
2.4.3. Calibration gasses.....	28
2.4.4. Instrument Air Input.....	28
2.5. ELECTRICAL CONNECTIONS	28
2.5.1. Analyzer electronics (ATEX application).....	28
2.5.2. Analyzer electronics (NEC US application).....	29
3. IN OPERATION.....	29
3.1. START-UP SAMPLE CONDITIONING SYSTEM.....	29
3.1.1. Inspection, visual and external connections.....	29
3.1.2. Air orifice selection.....	30
3.1.3. Opening of shut-off valves	30
3.1.4. Setting of gas pressure reducer.....	30
3.1.5. Adjusting flow with flow meters	30
3.1.6. Adjusting booster relays.....	31
3.2. START-UP OF THE CONTROL UNIT.....	32
3.2.1. Description.....	32
3.2.2. Programming the measurement parameters.....	32
3.2.3. Main screen.....	33
3.3. PROGRAMMING MENUS	37
3.3.1. Calibration Menu.....	37

3.3.2.	Operation Menu	37
3.3.3.	Measurement Menu.....	38
3.3.4.	Output Menu	39
3.3.5.	Communications Menu.....	41
3.3.6.	System Menu.....	42
3.3.7.	Reset Alarms Menu.....	44
3.4.	TEMPERATURE CONTROLLED OVEN.....	44
3.4.1.	Furnace temperature control unit.....	44
3.4.2.	Adjustment procedure temperature regulator	45
4.	PREVENTIVE MAINTENANCE	46
4.1.	WEEKLY, MONTHLY, THREE (3) MONTH MAINTENANCE.....	46
4.1.1.	Filters.....	46
4.2.	ANNUAL MAINTENANCE.....	46
4.3.	TROUBLESHOOTING.....	47
4.4.	REPLACEMENT OF RESIDUAL OXYGEN SENSOR AND CELL HOUSING	48
5.	MODBUS REGISTER LIST	54
5.1.	COIL REGISTERS	54
5.2.	DISCRETE INPUT REGISTERS	55
5.3.	INPUT REGISTERS.....	56
5.4.	VARIABLE LIST.....	69
6.	INSTALLATION DRAWING	70
7.	ORDERING OF SPARE PARTS	71
7.1	9610CXc Standard Temperature Spare Parts List as of 5-2021	71
7.2	9610CXc Mid Temperature Spare Parts List as of 5-2021.....	73
8.	LABELS	76

1. INTRODUCTION

1.1. INTRODUCTION

1.1.1. Purpose of the analyzer

The continuous 9610CXc™ analyzer determines online the Wobbe-index of a gas. The 9610CXc™ can be used both, as feed forward and feedback analyzer for gases mixing or as a feed forward analyzer for burning control. In order to achieve an optimal performance of the analyzer system it is necessary to read this manual thoroughly before installation and start-up.

For the combustion of gas, air is required. When supplying the right quantity of air, the gas will completely burn. This is the so-called stoichiometric air requirement of the gas. Because of this, the Wobbe-index can also be seen as a value for the need of air in gas. By burning the gas with a small excess of air, the flue gas will contain the remaining oxygen from the air, which has not taken part in the combustion. When the Wobbe-index of a gas changes, the stoichiometric air requirement, and the percentage of the remaining oxygen in the flue gas will change simultaneously. By measuring the concentration of oxygen in the flue gas, after calibrating the instrument with two gasses with known Wobbe-index, the Wobbe index can be calculated.

1.2. SPECIFIC CONDITIONS OF USE

1. Supplied voltage must not exceed 250 Vrms or 250 Vdc.
2. To prevent the risk of electrostatic sparking, the exterior of the equipment shall be cleaned only with a damp cloth.
3. Disconnect power from the Density Meter before servicing.
4. Do not connect USB port and Power simultaneously on the Density Meter.
5. The Density Meter enclosure contains aluminium. Care must be taken to avoid ignition hazards due to impact or friction.

1.3. THE 9610CXc™ ANALYZER

The 9610CXc™ features fast response time and high accuracy. These features make it unique over conventional Wobbe index analyzers. The oxygen concentration in the air is considered as constant, namely 20.95%. Functionally we can divide the analyzer-unit in 3 major parts:

- Sample System
- Electronics compartment

- Oven compartment

Optionally the 9610CXc™ can be built in an explosion proof execution. In explosion proof execution, the analyzer is protected with a purge system.

WARNING - Potential Electrostatic Charging Hazard.

Due to the materials construction of the viewing port, there is a potential to build up an electrostatic charge across the surface. Suitable precautions should be taken to reduce this risk.

1.3.1. Oven with oxygen sensor

The gas/air mixture is burnt catalytically in an oven, which is kept at 812°C with a heating spiral. The temperature is maintained with temperature control using a K-type thermocouple. The oxygen sensor in the oven is a zirconium oxide cell. This is mounted such, that one side is in contact with the outside air and the other side with the flue gasses. At high temperatures, (600°C) O₂-ions in the ZrO₂ grating become mobile through vacancies therein. By fixing porous Pt-electrodes at both sides of the ZrO₂, O₂ gas molecules can, through diffusion by and uptake of two electrons from the Pt electrode, enter the ZrO₂ as O₂-ion, move to the other electrodes, and be converted in gaseous O₂ again by release of the two electrons.

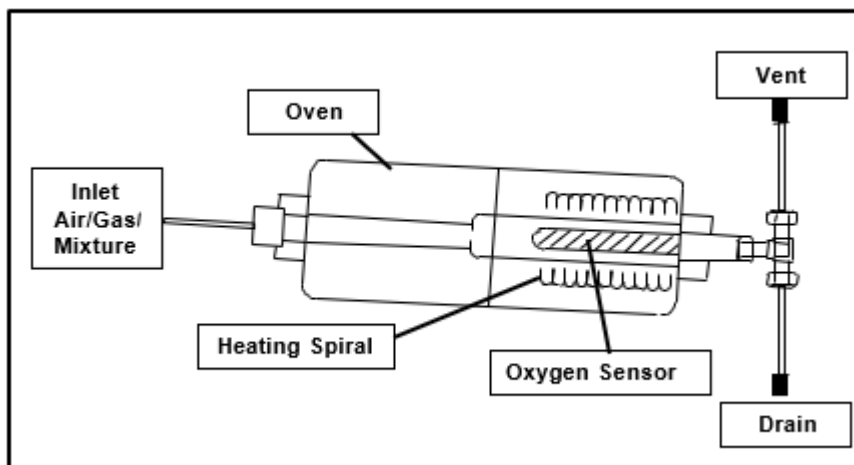

1.3.2. The sample system (SCS)

In the sample conditioning system (SCS), gas and air are mixed in a constant proportion, such that a small excess of air is present ($\pm 2.5\%$ oxygen) in the flue gas. The gas and air pressure are equalized by a dome-loaded pressure reducer (or booster relay), where the gas pressure governs the air pressure.

The booster relay has a temperature reducing effect; the gas/air mixing proportion can therefore vary as consequence of variations in viscosity. Therefore, the temperature of the

gas and the air are equalized in a heat exchanger. The gas and air temperature are still at surrounding temperatures, however, as long as gas and air fluctuate to the same extent this hardly influences the mixing proportion. In case of large surrounding temperature fluctuations, the calibration sequence has to be performed more often. Hereafter gas and air are mixed in the mixing chamber. The mixing chamber is equipped with orifices in the inlet nozzles. The gas and airflow are determined by a critical expansion over the orifices. The turbulence created provides a homogeneous mixture.

The diameter ratio of the orifices, together with the ratio between gas and air pressure, determine the mixing proportion.

After the mixing chamber, the mixture flow is divided into an excess flow to vent and a flow to oven. The flow to the burning oven will be approximately 30-50 NI/hr (500 - 800 Ncc/min). The vented stream is approximately 500 NI/hr (8000 Ncc/min) with a maximum 1000 NI/hr (16,000 Ncc/min).

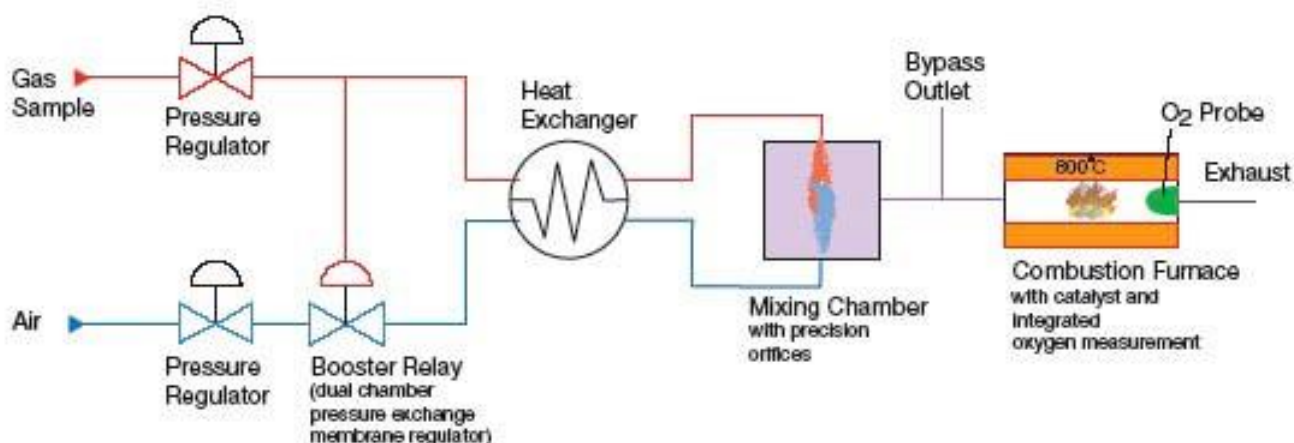

1.4. CALIBRATION PROCEDURE

The analyzer can be calibrated in three different ways:

- Single point calibration
Only one calibration gas is used. The value of the gas is chosen middle of the measuring range. This is only used to correct any offset error to the measurements.
- Two-point calibration
Two calibration gases are used. The low calibration gas is set at $\pm 20\%$ of the measuring range. The high calibration gas is set at $\pm 80\%$ of the measuring range. The advantage over a single point calibration is the increased accuracy over the entire span.

- Three-point calibration
This method uses three calibration gases and is mandatory for a dual range analyzer. The medium range calibration gas must be in the middle of the measuring range.

All three calibration methods can be performed both manually and automatically:

- Manually

The operator navigates the procedure via on-screen menu to open the correct gas valves to the analyzer. The operator controls the timing.

- Automatically

The analyzer itself controls the timing of the valves switching. When the measured values stay within the specified tolerances, the newly calculated calibration parameters will be accepted. Otherwise, the analyzer will keep the old value and generates a CAL ERROR on the display and switch the system fault contact and calibration fault contact.

The automatic calibration can be started as followed:

- Programmable time schedule (Timed calibration)
- Initiated manually via on-screen menu (Semi-automatic calibration)
- External host activates the calibration request contact (Remote calibration)

The one-point calibration/validation procedure will be executed as followed:

1. Analyzer activates calibration/validation contact.
2. The procedure pauses for the specified "Calibration Start Delay" time for the external host to prepare for calibration/validation.
3. Process gas is switched off and the calibration gas is switch on.
4. The analyzer waits for the readings to stabilize up to the "Switch Time".
5. Calibration gas is switched off and the process gas is switched on.
6. Analyzer deactivates calibration/validation contact.

The two-point calibration/validation procedure will be executed as followed:

1. Analyzer activates calibration/validation contact.
2. The procedure pauses for the specified "Calibration Start Delay" time for the external host to prepare for calibration/validation.
3. Process gas is switched off and the low calibration gas is switch on.
4. The analyzer waits for the readings to stabilize up to the "Switch Time".
5. Low calibration gas is switched off and the high calibration gas is switched on.
6. The analyzer waits for the readings to stabilize up to the "Switch Time".
7. High calibration gas is switched off and the process gas is switched on.
8. Analyzer deactivates calibration/validation contact.

The three-point calibration/validation procedure will be executed as followed:

1. Analyzer activates calibration/validation contact.
2. The procedure pauses for the specified "Calibration Start Delay" time for the external host to prepare for calibration/validation.
3. Process gas is switched off and the low calibration gas is switch on.
4. The analyzer waits for the readings to stabilize up to the "Switch Time".
5. Low calibration gas is switched off and the medium calibration gas is switched on.
6. The analyzer waits for the readings to stabilize up to the "Switch Time".
7. The analyzer switched the gas stream to the high range mixing chamber.
8. The analyzer waits for the readings to stabilize up to the "Switch Time".
9. Medium calibration gas is switched off and the high calibration gas is switched on.
10. The analyzer waits for the readings to stabilize up to the "Switch Time".
11. High calibration gas is switched off and the process gas is switched on.
12. Analyzer deactivates calibration/validation contact.

Between each step of the calibration process a switch time is programmed enabling the analyzer to stabilize. After the switch time the new value is used in the calibration algorithm. The calibration gas switch time is user programmable. By default, it is set at 120 seconds. Depending on the distance to the calibration gases it may be necessary to change to a longer or shorter delay.

1.5. EXTENDED (DUAL) RANGE OPTION

1.5.1.Operation

When the measuring range of the analyzer is larger than 1150BTU/SCF, an extended range option is available which covers a Wobbe index of 2730.BTU/SCF. This is accomplished by adding a second gas-mixing orifice and selection valves to make changeover possible.

The dilution ratios of each mixing orifice are chosen such that the measuring ranges overlap.

Via the software it is possible to create a 4/20mA current loop signal that covers the whole range. It is necessary to establish a switch over point that must be calibrated. For this reason, the calibration system is expanded with an extra solenoid valve.

1.6. SPECIFICATIONS 9610CXc™ WOBBE INDEX ANALYZER

1.6.1.Analyzer performance

Make	Process Insights
Service	Natural gas, fuel-gas, biogas, etc.
Ranges	Wobbe index 0-2730 BTU/scf (0-102 MJ/Nm ³), span 0-1150 BTU/scf (43 MJ/Nm ³) (selectable)
	CARI 0-20, span 0-10
Accuracy	± 0.4% of measuring value natural gas
Repeatability	±0.7 BTU/scf (±0.03 MJ/Nm ³)
Drift	< 0.4 BTU/scf (< 0.01 MJ/Nm ³)/ 24 hours
Response time	T90 < 5 seconds†
	T90 > 10 second with Density Cell
Output	2 isolated 4-20 mA outputs, 4 outputs total optional
	Span and service selectable
	Display & Optional Digital Output/ RS485, TCP/IP
	8 User-programmable contact relays
Safety	General area

† Wobbe w/o density cell or with streaming S.G. option

1.6.2. Utilities

Power supply	110 VAC, 50/60 Hz or 230 VAC/50 Hz
Power consumption	1260 VA to 3000 VA maximum based on options
Instrument air	20 SCFH (566 SLPH) (base analyzer) at 60psig
	40 SCFH (1,133 SLPH) (z-purge) at 80psig
	50 SCFH (1416 SLPH) (x-purge running) at 80psig
	1000 SCFH (2832 SLPH) (x-purge 8-minute start up) at 80psig 444 SCFH (12,579 SLPH) (purge and vortex system) at 80psig
Sample	2 SCFH (0.94 SLPM) at 28psig

1.6.3. Installation

Mounting	Freestanding Frame.
Dimensions	40.8 x 40.8 x 16.3 inches (1000 x 1000 x 400 mm)
Weight	Up to 450 lbs (204 kg). Shipping weight 750 lbs (340 kg)
Ambient temperature	50 to 104° F (10 to 40 °C)
	Extended range to -40 to 140°F (-40 to 60°C) With Heater and Vortex Cooler options in electronics cabinet
	Allow ambient temperature variation: ±45°F (7 °C) per 24 hours
	Sunshade or three-sided shelter recommended were possible
Humidity	0-90%

1.6.4. Connection

CONNECTION	SERVICE	SIZE	DESCRIPTION	MAT'	NOTE
N1	PROCESS GAS	1/8" OD	COMPRESSION FITTING	SS-316	
N2	CALIBRATION GAS LOW	1/8" OD	COMPRESSION FITTING	SS-316	
N3	CALIBRATION GAS MID	1/8" OD	COMPRESSION FITTING	SS-316	IF APPLICABLE
N4	CALIBRATION GAS HI	1/8" OD	COMPRESSION FITTING	SS-316	
N5	INSTRUMENT AIR	1/2" OD	COMPRESSION FITTING	SS-316	
N7	ATMOSPHERIC VENT (GAS BYPASS)	1/4" OD	COMPRESSION FITTING	SS-316	
N8	ATMOSPHERIC VENT (VENT FROM OVEN))	1/4" OD	COMPRESSION FITTING	SS-316	

1.7 X-Purge Option



1.7.1. Purpose

The 9610CXc™ Calorimeter is protected by a Pepperl & Fuchs X-purge unit. The purge Type X and Ex px purge pressurization system protects general-purpose equipment mounted in a standard enclosure so that it can be located and operated in a hazardous area. The hazardous area classification can be Class I and/or Class II, Division 1/Zone 1 and/or Zone 21. The X-purge operates by controlling and monitoring compressed instrument air through the protected enclosure(s) to remove and prevent the accumulation of flammable gas, vapors, or dust.

The X-Purge system features these main parts:

- Electronic processor (EPCU) housed in an explosion/flameproof enclosure
- I.S. electrical/pneumatic manifold assembly
- Input/output connections and controls for operation
- I.S. user interface for programming and monitoring the system
- 316L stainless steel type 4X IP66 enclosure for EPCU and connections
- Pressure relief vent with flow and pressure monitoring at the exhaust

The user interface allows programming of up to 4 switch inputs, temperature modules, enclosure power contacts, 2 auxiliary outputs, and various operational functions. Also, the

user interface screen allows monitoring and easy setup of configurable variables. With the user interface menus, configuration of the standard information for setup and operation of a

system such as purge time, flow rates, pressures, and enclosure size are easily programmable. Additional features allow Class I and Class II operation, inputs for system bypass, enclosure power on/off, temperature overload and activation of Rapid Exchange flow for cooling or auxiliary relay for separate cooling source, delay power shutdown, and much more. The two auxiliary contact outputs can be configured to activate on most of the input switches or any of the configured alarm states for pressure, flows, and temperature.

The power for the solenoid valve on the manifold unit, inputs, and EPV-6000 vent are provided by the EPCU through the internal, galvanically isolated intrinsic barrier. No additional intrinsic safety barriers are required for annunciation.

The X-Purge provides a complete system for purging and pressurizing enclosures for hazardous location operation.

The X-Purge system can be set up for Class I/ Division 1 (Zone 1), Class II/Division 1 (Zone 21), or both Class I & Class II/Division 1 (Zone 1 & Zone 21) applications in accordance with

the NEC-NFPA 70, NFPA496, ISA 12.4, IEC61241-4, and EN60079-2. This system also complies with IEC61508, SIL 2 level of integrity with SIL 3 option available.

1.7.2. Operation of X-purge and component kits

1.7.2.1 Operation

The X-Purge consists of the control unit and user interface mounted in a 316L stainless steel Type 4X (IP66) enclosure with the pneumatic solenoid valve mounted on the unit. A proportional valve can be ordered in place of the solenoid valve for continuous control of flow and pressure to the enclosure.

The EPV-X-Purge relief vent is separate and is mounted to the enclosure. The components of the X-Purge control unit are listed below:

- EPCU mounted in an explosion/flameproof enclosure
- I.S. user-interface with display and cable
- I.S. termination board (does not come with 'CK' kit version)
- Manifold with I.S. solenoid valve (does not come with 'CK' kit version)
- Flush mount type 4X IP66 fitting for protective gas supply to enclosure with tube attached
- Type 4X cable glands for I.S. wiring to I.S. inputs, vents, and temperature modules
- 316L stainless steel pipe nipples for power wires
- 316L stainless steel type 4X enclosure for the X-Purge controller

The components of the EPV-6000 vent:

- EPV-6000 vent with spark arrestor screen
- 1½” sealing nut with gasket for attachment of vent to customer’s enclosure
- One 5 meter, quick disconnect cable; blue (denoting I.S.), for connection to I.S. termination board inside X-Purge control unit

The X-Purge control unit and vent are mounted to the calorimeter enclosure. Bottom, right side mounting can be completed with only one control unit and vent. One unit is used for enclosure sizes up to 450 ft³ (12.7 m³).

1.7.2.2. Electronic Power Control Unit – EPCU

The EPCU houses the redundant microprocessors, enclosure power contacts, (2) auxiliary contacts, power supply module, galvanically isolated barriers for the inputs, vent(s), and temperature modules; all stackable and easy to remove and install into the explosion proof enclosure that houses them.

The power supply module is available in 24 VDC or 100-240 VAC units. The enclosure power contacts are forced-guided safety relays. The auxiliary contacts can be user configured for different functions depending on user requirements.

1.7.2.3. User-Interface Controller – UIC

The X-Purge is user programmable for many of the configurable options available. This is done with the intrinsically safe user-interface on the face of the unit, which can also be remote mounted. The user-interface is a 2 x 20 LCD that is programmed through a set of buttons on the menu driven unit. All configuration and options are programmed through this unit. There are also (5) LEDs for easy visual indication of operation:

- Safe Pressure – This turns on (blue) when safe pressure is achieved inside the enclosure.
- Enclosure power – This is (red) when the enclosure power is off, and (green) when enclosure power is on. The enclosure power can be on only after a successful purge and a safe pressure is achieved. Bypass option allows power to remain on if safe pressure is lost.
- Rapid Exchange® – The Rapid Exchange or purging flow rate turns on (blue) when the flow rate is measuring proper flow.
- System Bypass – This turns on (yellow) when the system bypass is active. This should be used only when the area around the enclosure is known to be safe.
- Alarm Fault – The (red) LED blinks when any alarm input is detected and is solid when

there is an internal system fault.

1.7.2.4. Pneumatic Manifold with I.S. Solenoid

- Manifold with I.S. solenoid valve: The manifold system is mounted on the 6000 control unit providing a needle valve to set enclosure pressure and an I.S. solenoid valve that is used for purging (Rapid Exchange). Power for the I.S. solenoid valve is provided by the EPCU and is galvanically isolated. Regulated instrument-grade air is required.
- Proportional valve option: The I.S. proportional valve is separated on the 6000 control unit and provides continuous flow and pressure to the enclosure for purging (Rapid Exchange) and pressurization. Power for the I.S. solenoid valve is provided by the EPCU and is galvanically isolated. No needle valve is required. Pressures can be controlled from a user set-point.

Certifications allow the X-Purge to be used on enclosures in a gas hazardous atmosphere. Gas atmospheres require the purging of the enclosure. Dust atmospheres require the physical removal of all the dust that collects inside. Both gas and dust atmospheres require the following:

- 1) removing the dust,
- 2) sealing the enclosure, and then
- 3) purging the enclosure.

After these sequences, the pressure within the enclosure is above the minimum level. The equipment within the enclosure can be energized.

1.7.2.5. Purge Timing

When using the X-Purge in a gas or gas and dust location, the time for purging an enclosure can be based either on a known purge rate and time (fixed purge time), or based on the flow rate being measured from the vent (dynamic purge time). Both methods base the time on the flow measurement at the vent and complete the process in steps. The EPCU will take

the readings from the vent and use the appropriate reading (listed below) as the useable flow rate. For example, if the flow rate measurement from the EPV-6000 vent is 7 SCFM, the EPCU will use 5 SCFM as the flow rate for evaluation. The flow rate measurement steps and corresponding enclosure pressures are as follows:

- 5 SCFM @ 1.3" w.c. , (141 l/min @ 33 mm w.c.)
- 12 SCFM @ 2.5" w.c., (340 l/min @ 64 mm w.c.)

- 20 SCFM @ 3.1" w.c., (565 l/min @ 77 mm w.c.)
- 30 SCFM @ 3.4" w.c., (850 l/min @ 86 mm w.c.)

The 9610CXc™ uses the first setting of 5 SCFM @ 1.3" w.c. to establish the purge within the enclosures. This volume exchange and purge timing is factory set to 8mins, but can be re-configured to a different value if required by the Area Authority having jurisdiction at the installation site.

1.7.2.6. Fixed Purge Time

If the purge time must be held to a specific time, then this time is based on the known enclosure volume, number of volume exchanges, and flow rate through the vent. If the flow rate is below the required minimum, then the purging cycle will reset and will not start until the flow rate is above the selected rate. This set up does not allow purge flow to go below the value required and will not recalculate the time for purging if it goes above the required purge rate.

1.7.2.7. Dynamic Purge Time

Dynamic purge time allows the purge time to be updated to the purge flow through the vent. This method is not dependent on a constant flow from the protective gas source. It bases the purge time on the measured flow and not a set flow. This is very useful when the protective gas supply pressure varies throughout the purging cycle or when it may vary from one installation to another.

The following parameters must be entered for the dynamic purge time:

- Enclosure volume
- Number of exchanges

The purge time will be based on the measurement of the vent and evaluation of this measurement from the EPCU. This allows recalculation of the time based on this

measurement. During the dynamic purge time, the user-interface will display the purge time in a percentage starting with 0% and ending with 100% (purge time complete).

1.7.2.8. Purging Modes

Purging start-up can be set up in 4 different modes, which are explained below:

- STD – Standard mode requires the operator to engage the manifold solenoid valve

manually when purging and manually disengage when a successful purging is complete.

- SA – Semiautomatic mode requires the operator to engage the manifold solenoid valve manually when purging. The EPCU will automatically disengage when a successful purging is complete.
- FA – Fully-automatic mode will automatically engage the manifold solenoid valve when safe pressure is detected and will automatically disengage when a successful purging is complete.
- PV –The proportional mode will continuously control the flow rate during and after purging. This allows maximum efficiency of the protective gas supply. This is very useful for areas where there is a limited amount of the protective gas supply available.

1.7.2.9. Inputs

There are (4) intrinsic safety inputs for activation of various outputs and actions by the EPCU. These inputs accept only a dry contact for activation and are supplied by the EPCU's galvanically isolated barrier. The assignments of the inputs for various actions are achieved through the user-interface controller. Only one function can operate an input. These inputs can bypass the system for live maintenance on the enclosure.

The intrinsic safety inputs activate the auxiliary relays, energize the Rapid Exchange valve, de-energize the enclosure contacts, and shut the system down, in addition to many more actions and outputs.

1.7.2.10. Outputs

There are (2) normally open dry contacts for the enclosure power that can be energized only after a successful purging and a minimum enclosure pressure is maintained. Loss of pressure will cause the contacts to de-energize unless the shutdown timer is active, or bypass mode is implemented.

Also available are the Auxiliary 1 and Auxiliary 2, SPDT dry contact outputs. The auxiliary outputs can be user configured using the user-interface controller and are controlled by various inputs or various conditions such as low pressure, loss of pressure, bypass implemented, Rapid Exchange valve on, enclosure above maximum pressure setting, and many more. Both enclosure contacts and auxiliary contacts are forced-guided safety relays for functional safety.

1.7.2.11. EPV-6000 I.S. Relief Vent

The EPV-6000 vent exhausts excess pressure from the enclosure if the pressure within the enclosure is above 1.0" w.c. and measures flow and pressure during operation. The X-Purge vent has a pressure transducer and thermal flow sensor that is connected to the 6000 EPCU and is intrinsically safe through the galvanic isolation barrier within the EPCU. Because measurement of the flow is always at the exhaust of the pressurized enclosure, the vent is located on the enclosure(s) such that it is venting to the atmosphere. The vent is connected to the I.S. termination board using the V1 connector and cable that comes with the vent. The EPV-6000 vent can be mounted vertically or horizontally and is not gravity dependent. For corrosive environments, the EPV-6000 has an optional stainless-steel cap so that the body of the vent is mounted in the enclosure with just the stainless steel cap exposed to the outside environment.

The I.S. termination board is mounted inside the Type 4X (IP66) stainless steel enclosure and does not require any lead seals to the EPCU enclosure. Wiring from the EPCU to this I.S. termination board is provided. The power connection for enclosure power, auxiliary outputs and power to the EPCU is completed within the explosion proof enclosure that houses the EPCU. A stainless steel ¾" conduit extends to the outside of the Type 4X, IP66 stainless steel enclosure for easy connection of the lead seals. Lead seals or Ex de cable glands are not provided. Any certified lead seal or Ex de cable glands can be used. No special seals are required. See X-purge manual for electrical connections.

1.8 Z-Purge Option

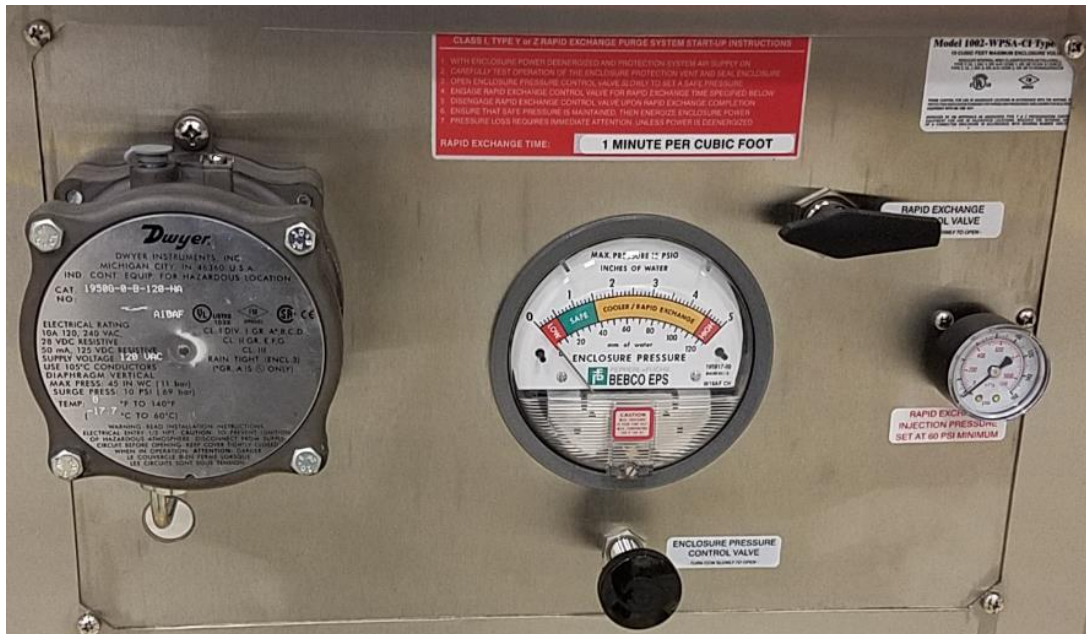

1.8.1 Purpose

The 9610CXc™ Calorimeter is protected by a Pepperl & Fuchs' Bebc0 EPS system type Z rapid exchange purging system, model 1002. It allows the use of general purpose or nonrated non-rated electrical or electronic devices, with exception to devices that produce excessive heat, utilize combustible gas, or expose arcing contacts to the hazardous atmosphere, in NEMA (National Electrical Manufacturers Association) 4 or 12 enclosures in the place of explosion proof NEMA 7 enclosures. Other purposes include heat, moisture and dust contamination prevention.

The purge Type Z pressurization system protects general-purpose equipment mounted in a standard enclosure so that it can be located and operated in a hazardous area. The hazardous area classification can be Class I, Division 2, Group B, C, D. The Z-purge operates by controlling and monitoring compressed instrument air through the protected enclosure(s) to remove and prevent the accumulation of flammable gas, vapors, or dust.

The Z-Purge system features these main parts:

- Enclosure pressure gauge
- Enclosure pressure control valve
- Rapid exchange control valve
- Rapid exchange pressure gauge
- Venturi orifice

- Regulator
- EXP pressure loss alarm switch

1.8.2. Operation

With the inert gas supply connected, enclosure power deenergized and alarm system energized (if utilized).

1. Carefully read start-up instruction nameplate on system.
2. Check operation of the enclosure protection vent (model EPV-2), opening it manually several times.
3. Seal protected enclosure.
4. Open enclosure pressure control valve, by turning CCW, to set enclosure pressure gauge at "safe" pressure, the pressure loss alarm switch should then activate to silence the alarm system (if utilized).
5. Ensure the protection system enclosure pressure gauge maintains a "safe" pressure for one (1) minute.
6. Open Rapid Exchange control valve fully by turning 90° CCW and quickly ensure the enclosure protection vent opens. Note: The enclosure pressure gauge should move quickly off scale to the right, this is normal for all Rapid Exchange purging systems.
7. Standby for the exchange time as specified on the start-up instruction nameplate (five minutes minimum), then close the Rapid Exchange control valve fully.
8. Wait for the enclosure pressure gauge to return to a "safe" pressure and energize the protected enclosure power via the local disconnect switch.
9. Ensure the enclosure pressure indicator maintains a "safe" pressure before leaving system unattended.

1.9 Flow alarm

The flow alarm is an ABB Automation Series 10A6100 Purgemaster™ meter. It is a low capacity, glass tube type, variable area meter used to measure and visually indicate the flow rate of liquid or gas. A metallic ball is used in this alarm flowmeter.

The Purgemaster™ meter used in The 9610CXc™ Calorimeter is equipped with a min alarm contact. The alarm sensor is suitable for hazardous location because the sensors are intrinsically safe when used with the switching amplifier.

The 9610CXc™ Calorimeter alarm flowrate is set at **10NI/min.**

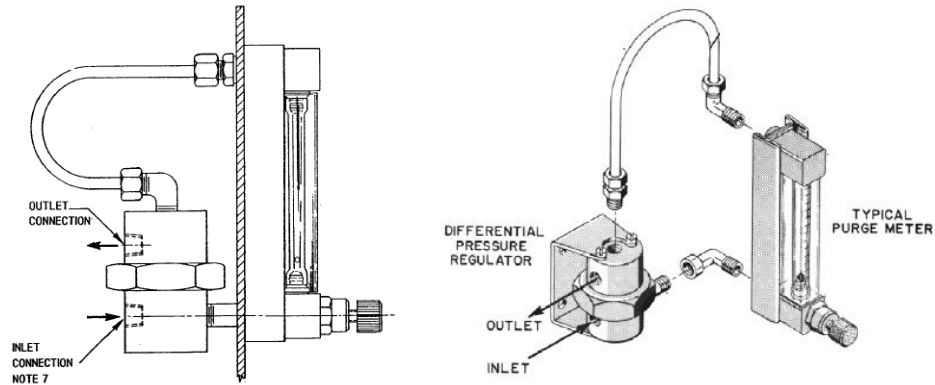

The alarm consists of a Pepperl and Fuchs ring sensor (that encircles the meter tube) and a remote mounted Pepperl and Fuchs switching amplifier with the response time of approx. 20 milliseconds. The sensor with bistable switching action uses the position of the ball float as the input signal for actuation. It is adjustable over the metering range of the tube. The sensor can be adjusted using a 1.5 mm hex socket wrench to loosen the locking screws and sliding the sensor up or down on the meter tube. Re-tighten the locking screws.

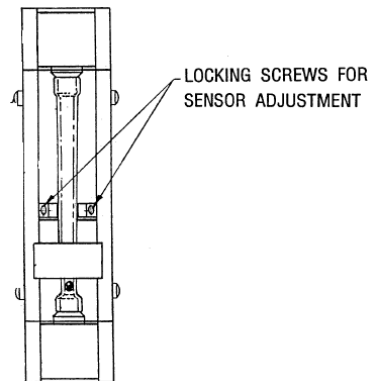

Maintenance

The maintenance required are the cleaning the tube, float, and operator protection shield. The meter should be cleaned frequently enough to assure accuracy and float visibility.

Follow the Purgemater™ instruction manual to maintenance the alarm flowmeter.

2.0 System maintenance

Maintenance and installation are performed by trained personnel only. Please contact Process Insights

for the maintenance schedule.

Regular Maintenance

Drain the protection system regulator frequently and clean system with nonsolvent cleaning agents only.

Long-Term Maintenance

Calibrate the enclosure pressure indicator to 0 inches by venting the purge pressure reference port and the protected enclosure to atmosphere and adjusting the calibration screw in the lower center portion of the indicator's face.

Fully open the enclosure pressure control regulator, to blow out any deposits around the tip of the valve and to ensure that the enclosure protection vent is operating properly, then carefully readjust system according to the set-up procedure and operating sequence on pages 16 and 17 of "X-Purge Installation and Operation Manual". Replace or tighten stem packing nut as required to prohibit stem packing leakage.

Carefully disassemble the enclosure protection vent by loosening the two bottom hex nuts that hold the unit together.

(DO NOT REMOVE CAP NUTS ON TOP OF VENT BODY)

Carefully clean the flapper valve and vent body seats with warm soap and water, being careful not to extend the vent valve beyond its normal opening point and being careful not to exert any stress on the valve hinge.

Examine the entire protection system and the protected enclosure and replace any defective parts during routine shutdown of the protected enclosure(s). Parts are available from Pepperl+Fuchs on immediate notice as required.

2. INSTALLATION

2.1. GENERAL

Upon receipt and unpacking of the 9610CXc™ a visual inspection must be carried out to check for any visual damage, caused by transport. Any damage must be reported immediately to:

Process Insights CORPORATION

Texas Office:

Building 6, 14400 Hollister Street Suite 800-B
Houston, TX 77066
Tel: 713-947-9591
Fax: 713-947-7549

New York Office:

84G Horseblock Rd.
Yaphank, NY 11980
Tel: 631-345-3434
Fax: 631-345-5349

E-mail:

support.hou@process-insights.com

We kindly ask you to submit photographs of the damage.

If the 9610CXc™ is supplied by PROCESS INSIGHTS, as part of a complete package and built into a shelter or house, installation may differ from hereunder described.

2.2. STORAGE

The 9610CXc™ must be stored frost-free and at a maximum temperature of 122°F (50°C), preferably in its original packing, and protected against direct sunlight and (rain) water.

2.3. PLACEMENT

2.3.1. General

The 9610CXc™ can operate under ambient conditions between +50° F (10°C) and +104°F (40°C) with extended ranges of -40 to 140°F (-40 to 60°C) with added options and a maximum humidity of 90%. For extended life of the analyzer and components a sunshade or three-sided shelter is recommended.

2.3.2. 9610CXc™ in general purpose execution

The 9610CXc™ is mounted to a freestanding stainless-steel frame. Fixing lugs are located on each corner of the cabinet. Fixings used must be suitable for the weight of the 9610CXc™ (±331 lbs/150kg).

The 9610CXc™ must be mounted on such a level above the floor or underneath located obstacles that the oven drain can be connected to a drain header or a condense bottle.

The 9610CXc™ is supplied on a 304SS freestanding frame. This frame is to be placed on a flat surface (i.e. concrete slab). Two holes in the base of the frame enable the 9610CXc™ to be fixed to the floor.

2.4. MECHANICAL CONNECTIONS

2.4.1. General

- Location and number of connections may vary depending on type and execution of the analyzer. See the project specific drawings of your order.
- Tubing connections on the 9610CXc™ are Swagelok double ferrule compression type fittings for imperial sizes. Reducers to metric fittings or NPT thread are available.
- Only seamless and annealed imperial size instrument tubing according to ASTM A-249 at a maximum permissible hardness of Rockwell B-90 may be used.
- Tubing must be cut off straight and de-burred thoroughly inside and outside of tubing cutting edge.
- The outside surface of the tube ends entering the fittings must be clean and free from scratches.
- Nuts and ferrules should not be removed to avoid mixing up of the nuts and or ferrules.
- Tubing must be pushed into the fitting onto the seat.
- Hand-tighten the nut and mark the nut against the fitting.
- Use a correct size wrench to lock the body of the fitting and tighten the nut with

another correct size wrench for 1- 1/4 turn for 1/4" fittings, 3/4 turn for 1/8" fittings. Watch the marks.

- Before connecting the tubing to the analyzer they must be blown through with dry nitrogen or instrument air to remove all particles.
- All connections must be checked against leakage prior to putting the analyzer in operation or installing the tubing.
- Pressurize the lines with nitrogen or instrument air at 7bar maximum to perform leak test. Check each connection with snoop or soap.
- Make sure before pressurizing for leak-test that the power to the analyzer is off (sample and calibration selection valves closed) and that the instrument air supply isolation valve in the analyzer is closed.
- Vent connections must not be pressure tested while connected to the analyzer. Disconnect and cap these tubes if leak test is required.
- Re-connection of the fittings is done by hand tightening the nut followed by wrench tightening for 1/4 turn.
- If a leak is detected, it might be fixed by tightening the fitting step by step a little more (up to a 1/4 turn) until it is tight. Then the fitting must be inspected if it has not been over-tightened. This is done by disconnecting the fitting and to check if the ferrules can still be rotated in relation to each other and the pipe. (If the ferrules can also be moved in an axial direction the fitting is too loose) If the ferrules are stuck, the pipe must be cut just after the nut and newly installed according above instructions using new ferrules. The nut can be re-used.
- If this does not solve the problem, remove the fitting, and inspect the fitting body for damage. If it is damaged the complete fitting must be replaced. If the body is not damaged, the pipe must be cut just after the nut and newly installed according above instructions using new ferrules. The nut can be re-used.
- Disconnected fittings can be re-installed by hand tightening the nut followed by wrench tightening for 1/4 turn. It is recommended to perform a leak test after re- installation.

2.4.2. Sample supply

The sample supply line must be heat-traced and/or insulated to keep the gas above dew point. Check your sample data for required temperature.

Sample inlet connection on the analyzer is identified with a tag-plate.

The sample connection on the analyzer is for 1/8" OD tubing. Tubing size to the process may require a different tube size, this should be determined taking into account process pressure, sample line length and acceptable lag time.

2.4.3. Calibration gasses

Calibration gas composition is depending on range and process gas. Process Insights can advise suitable compositions.

For a single range analyzer, two calibration gasses (low and high value) are recommended. For a dual range analyzer, three calibration gasses (low/medium and high value) are mandatory.

2.4.4. Instrument Air Input

Air supply must be compressed at minimum of 80 psi to 150 psi.

Filters and dryers should be installed to the air supply line to remove particulates, vapor, aerosols, and moisture as they may cause damage to the equipment.

2.5. ELECTRICAL CONNECTIONS

The 9610CXc™ requires one power supply.

2.5.1. Analyzer electronics (ATEX application).

The power must be connected on the interference filter inside the electronics cabinet. The cable must lead into the analyzer through a suitably certified cable gland. This power is supplied from the breaker panel that is in turn controlled by the X-purge unit.

2.5.2. Analyzer electronics (NEC US application).

The power must be connected on the interference filter inside the electronics cabinet. The cable must lead into the analyzer through a suitable approved conduit and conduit adapters.

The 9610CXc™ has multiple input and output signals, which can be split in two groups, analog and digital signals. For both groups, a suitably certified cable gland for use with multi core cables are foreseen for ATEX use and suitable conduit and conduit adapters for North American installation.

If more entries are required, only suitably certified cable glands or conduit adapters are allowed to be used and it must be made sure that they are in good electrical contact with the white personated sink layer on the electronics enclosure surface (paint locally to be removed with a detergent).

For termination details see project specific drawings.

3. IN OPERATION

3.1. START-UP SAMPLE CONDITIONING SYSTEM

The sample conditioning system is located in the left-hand compartment. This chapter describes how the components of the sample conditioning system should be set up, in correct order, so a perfect start-up of the total analyzer system can be achieved. The instructions hereunder should be performed step by step.

3.1.1. Inspection, visual and external connections

Perform a visual inspection of the system and close all shut-off valves in the system. Check the connecting fittings of the supply tubes to be correctly fitted and are not leaking. This can be checked quite simple by unscrewing the nut from the fitting and then check if "Front and Back ferrule" of the fitting is able to rotate but cannot be moved in an axial direction. If this is not the case, this tube must be renewed. Then turn the nut by hand and afterwards tighten it a 1/4 turn with a suitable spanner. The supply and drainage tube can now be connected.

Because the supply line is under pressure and has been closed off on the 9610CXc™

side, the connecting fittings can be squirted with soap in order to detect any possible leaks. When bubbles appear, this indicates a leak and the tube concerned must immediately be closed off at the supply point. Inspect the fitting and tube, replace components when necessary.

3.1.2. Air orifice selection

Before the 9610CXc™ is set into operation, the range of measurement must be established. The air orifice is selected based on the desired range of measurement.

The 9610CXc™ is standard equipped with the following orifices:

- Gas: .0079" to .018" (0.2 mm to 0.3 mm).
- Air: 0.55"/0.60"/0.65"/0.70"/0.75" for a dual range version extended with .80"/.85" and .90".

Relationship of pressure differential (gas/air) versus Wobbe-Index with different air orifices and a fixed residual oxygen concentration of 5% (theoretically determined).

It is therefore recommended that a residual oxygen concentration of 2.5% is chosen corresponding to the reference point. Possible fine-tuning of the reference point, (for the purpose of attaining the correct O₂ %); can be carried out by giving the booster relay a positive or negative offset.

3.1.3. Opening of shut-off valves

Open the shut-off valve with identification plate "instrument air supply".

3.1.4. Setting of gas pressure reducer

Turning the adjusting cap clockwise can raise the pressure of the gas pressure reducer. The set outlet pressure can be read immediately from the pressure indicator mounted on the reducer. Set the output gas pressure to 30 PSIG.

3.1.5. Adjusting flow with flow meters

Unscrew the needle valve of bypass flow regulator completely (turn CCW). Use the "By-pass flow meter" needle valve; throttle back the flow so that the "Analyzer flow meter" shows a flow of 50 liter/hr (800 CCM or 1.8 CFH). Noting that the max flow is

adjusted based on the application.

After this throttle back the output of the analyzer flow to 40 liter/hr (660 CCM or 1.4 CFH) using the needle valve on flow meter tagged "Analyzer flow".

3.1.6. Adjusting booster relays

Set the chosen residual O₂ set point with help of the booster relay. With the booster relay it is possible to give a small negative (i.e., the gas pressure is higher than the air pressure) or positive offset of max 0.5 bar, as set point correction or as pressure drop compensation over the air- and gas tubes in the heat exchanger.

To change the offset pressure, remove a plug on the top the top of the booster relay. Using a screwdriver slowly turn CCW until a decent negative offset is reached. In other words, the air pressure is lowered in comparison with the gas pressure. The correct choice of a negative rather than a positive offset needs to be used for proper analyzer operation. The chosen residual oxygen concentration, combined with the average of the chosen range of measurement, gives according to these curves the selection of the air nozzle and an indication for the booster offset.

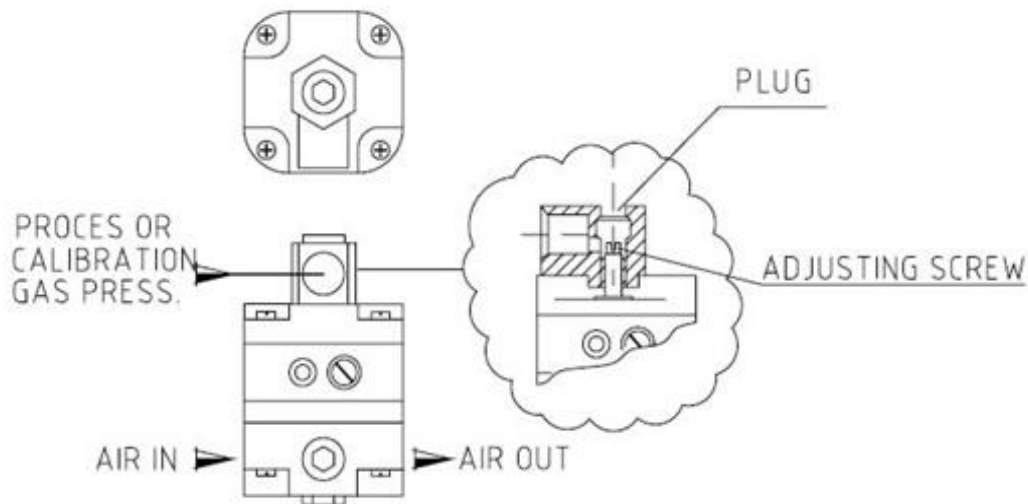

! Caution

The adjusting screw is located in the gas compartment of the relay. When the plug is released, gas will escape. Be prepared before the relay is going to be adjusted, e.g., have the right equipment readily available, so the gas compartment must be open for only a minimum of time.

After this adjustment, the plug must be re-installed, and the offset can be checked. The offset adjustment can be checked by reading the air and gas pressure indicators. This operation must be repeated until the desired residual oxygen concentration is reached. After installing the plug with a sealing tape, check for leakage by means of either a gas leak detector or soap.

It is advisable; to carry out a check on the booster relay adjustment with high Wobbe-Index calibration gas, directly after setting up the booster set point. Using the on-screen menu, select 2 Points manual (Dual Range manual for dual range analyzer) validation. Proceed to the "Wait for cal gas 2 to stable" step ("Wait for cal gas 3 to stable" for dual range analyzer). When the signals become stable, the display will show the Residual O2 mV-value suitable to this calibration gas. The setting of the booster relay is right when the mV-value stays below 67 mV. If not, a positive offset should be set with help of the booster relay, so that relative more air will be added and the mV value will fall.

The required Residual O2 mV-signal should be around 65mV for the highest expected Wobbe value.

3.2. START-UP OF THE CONTROL UNIT

This chapter describes the procedure to start up the control unit. When a machine is being started up for the first time a gas calibration must be done first.

3.2.1. Description

This chapter describes the procedure to start up the control unit. When a machine is being started up for the first time a gas calibration must be done first.

3.2.2. Programming the measurement parameters

Programming the 9610CXc™ is easy with the menu-controlled software. Menu can be navigated using the cursor keys. The key operations are:

Key	Menu navigation	Change setting value
** or Enter	Select menu item	Accept value change
# or Esc	Go back to previous menu	Undo value change
\$	Go up one menu item	Go to previous item value
%	Go down one menu item	Go to next item value

To enter the main menu screen, press **ESC** or **ESC**. Then screen now presents some functions that can be selected by the cursor keys or by typing the number associated to the menu item. To resume normal operation, press **#** or **ESC** until the main screen to appear. To change a setting value on menu, select the item and enter the new value. For setting item with selection (e.g., On/Off), select the desired value using **\$** and **%** keys.

3.2.3. Main screen

The main screen is divided into section, each representing data, status or charts as see in the figure below. Graphical chart trend data can be changed to any of the calorific, density or other values shown on the main screen.



The lower right section displays the status of each digital input and output. The signal assignments are user-programmable.

Explanation outputs

cal gas 1	Digital output driving low value calibration gas air actuator
cal gas 2	Digital output driving medium value calibration gas air actuator

cal gas 3	Digital output driving high value calibration gas air actuator
range 1 (optional)	Extended range execution indicating second mixing chamber is selected for dual range option
stream 1 (Standard)	Indicating process stream 1 selected
stream 2 (optional)	Indicating process stream 2 selected
Stream sw	Status, switching streams
High alarm	High Calorific value
Low alarm	Low Calorific value
Calibrate	Calibration in progress
Validate	Validation in progress
Calibration fault	Calibration fault
Sys fault	Collective alarm
In op	Analyzer is in operation
System Ok	Status box, also displays access level and fault

Explanation inputs	
Calibration req	External input to start calibration
Validation assignment	External input to start validation
Calibration gas pressure	Calibration gas pressure regulator (input)
Air pressure	Instrument air pressure regulator (input)
Sample pressure	Sample pressure regulator (input)
Flow alarm A (optional)	This digital input has no function at present
Flow alarm B (optional)	As above
Flow alarm C (optional)	As above
Flow alarm D (optional)	As above
Flow alarm E (optional)	As above

Global Settings

Menu Tree V2.3.0.0

1. Calibration

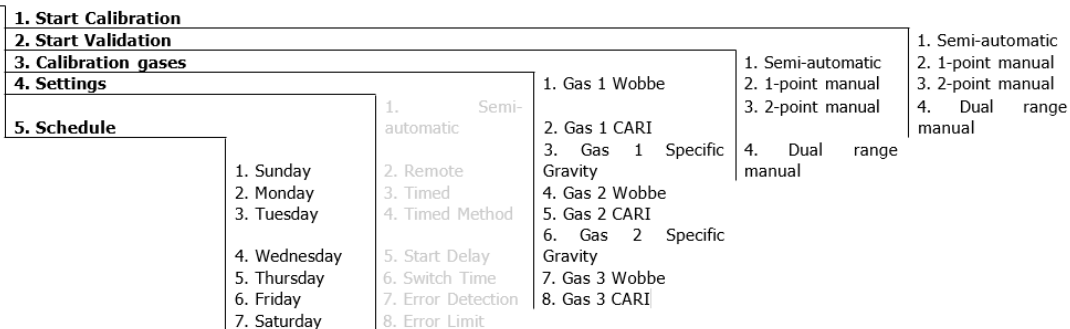

2. Operation

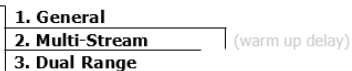

3.

Measurement

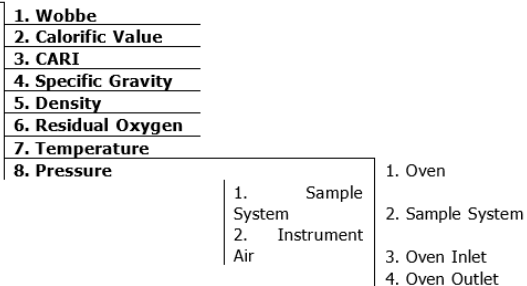

4. Output	(Analog & During Cal) 1. Channel A 2. Channel B 3. Channel C 4. Channel D
5. Communication	1. Modbus 2. Serial 3. Ethernet
6. System	1. About 2. Date & Time 3. Login
7. Display	1. Chart 1 2. Chart 2 3. Color
	4. Password
	(User Password 1234)
	5. Logout
	(Admin Password 9999)
	6. Configuration 7. Test
	8. Restart 9 Exit
	1. Analog Output A 2. Analog Output B 3. Analog Output C 4. Analog Output D 5. Digital Output 1-8 6. Digital Output 9-16 7. Digital Input 8. Digital Out Polarity 1-8 9. Digital Output Polarity 9-16 0. Digital Input Polarity
8. Reset Alarms	

3.3. PROGRAMMING MENUS

The paragraph numbers correspond with the key sequence from the 'menu tree'. In this way it is easy to see how a specific menu is reached. One exception is the measuring menu, this is reached from the main screen by either the  or **ENTER** key.

3.3.1. Calibration Menu

In the main menu, the following sub-menus are available:

1. Calibration			
1. Start Calibration			
2. Validation Settings			
3. Calibration gases			
4. Settings			
5. Schedule			
	1. Sunday	1. <i>Semi-automatic</i>	1. Gas 1 Wobbe
	2. Monday	2. <i>Remote</i>	2. Gas 1 CARI
	3. Tuesday	3. <i>Timed</i>	3. Gas 1 Specific Gravity
	4. Wednesday	4. <i>Timed Method</i>	4. Gas 2 Wobbe
	5. Thursday	5. <i>Start Delay</i>	5. Gas 2 CARI
	6. Friday	6. <i>Switch Time</i>	6. Gas 2 Specific Gravity
	7. Saturday	7. <i>Error Detection</i>	7. Gas 3 Wobbe
		8. <i>Error Limit</i>	8. Gas 3 CARI
			1. Semi-automatic
			2. 1-point manual
			3. 2-point manual
			4. Dual range manual



3.3.2. Operation Menu

- 2. Operation
 - 1. General
 - 2. Multi-Stream (warm up delay)
 - 3. Dual Range

4-1D-2DD9 12:14 COSA 9610

Wobbe	454.46	BTU/scf	Residual O2	16.34	mV
Calorific	345.55	BTU/scf	Spec Gravity	1.83	V
CARI	4.655		Power Supply	24.1	V
Spec Gravity	0.5782		Sample	49.0	°C
Density	0.0466	lbs/cf	Oven	812.0	°C
Residual O2	9.56	%	Elec. Cabin	32.3	°C

Operation	
1 General	cal gas 1 high alarm
2 Multi-stream	cal gas 2 low alarm
3 Dual range	cal gas 3 calibrate
	range 1 validate
	stream 1 range 2
	stream 2 cal fault
	valid 1 in op
	valid 2 sys fault
	watchdog ---
	cal req ---
	val req ---
	stream sw ---
	Admin access

3.3.3.Measurement Menu

- 3. Measurement
 - 1. Wobbe
 - 2. Calorific Value
 - 3. CARI
 - 4. Specific Gravity
 - 5. Density
 - 6. Residual Oxygen
 - 7. Temperature
 - 8. Pressure
 - 1. Oven
 - 2. Sample System
 - 3. Oven Inlet
 - 4. Oven Outlet
 - 9. Flow
 - 1. Sample System
 - 2. Instrument Air
 - 0. Sulfur
 - A. H2



3.3.4. Output Menu

4. Output

(Analog & During Cal)

- 1. Channel A
- 2. Channel B
- 3. Channel C
- 4. Channel D

4-10-2009 12:42		COXA 9610			
Wobbe	454.43	BTU/scf	Residual O2	18.34	mV
Calorific	345.53	BTU/scf	Spec Gravity	1.83	V
CARI	4.655		Power Supply	24.4	V
Spec Gravity	0.5		Sample	49.0	°C
Density	0.0466	lbs/cf	Oven	812.0	°C
Residual O2	9.56	%	Elec. Cabin	32.3	°C

Output		cal gas 1	high alarm
1 Channel A		cal gas 2	low alarm
2 Channel B		cal gas 3	calibrate
3 Channel C		range 1	validate
4 Channel D		stream 1	range 2
		stream 2	cal fault
		valid 1	in op
		valid 2	sys fault
		watchdog	---
		cal req	---
		val req	---
		stream sw	---
Admin access			

3.3.5. Communications Menu

5. Communication

- 1. Modbus
- 2. Serial
- 3. Ethernet

The screenshot shows the main status screen of the COSA 9610. At the top, it displays the date and time '4-10-2009 12:45' and the unit identifier 'COSA 9610'. The main display area is divided into two columns of data. The left column shows: Wobbe (454.41 BTU/scf), Calorific (345.52 BTU/scf), CARI (4.655), Spec Gravity (0.5782), Density (0.0466 lbs/cf), and Residual O2 (9.56 %). The right column shows: Residual O2 (18.34 mV), Spec Gravity (1.83 V), Power Supply (24.4 V), Sample (49.0 °C), Oven (812.0 °C), and Elec. Cabin (32.3 °C). Below the main display is a 'Communication' menu with three options: 1 Modbus, 2 Serial, and 3 Ethernet. To the right of this menu is a grid of control buttons including 'cal gas 1-3', 'range 1-2', 'stream 1-2', 'valid 1-2', 'in op', 'sys fault', 'watchdog', 'cal req', 'val req', 'stream sw', and 'Admin access'.

Submenus 1-3 with default communication settings

The first screenshot shows the 'Modbus' submenu with two settings: '1 Slave address' set to '2' and '2 32-bit form' set to 'Upper word first'. The second screenshot shows the 'Serial' submenu with three settings: '1 Baud rate' set to '19200', '2 Parity' set to 'Even', and '3 Timeout' set to '5000 msec'.

Ethernet		
1 Address	196.168.0.1	
2 Subnet Mask	255.255.255.0	
3 Gateway	196.168.0.0	
4 Timeout	5000	msec
5 Port	502	

3.3.6. System Menu

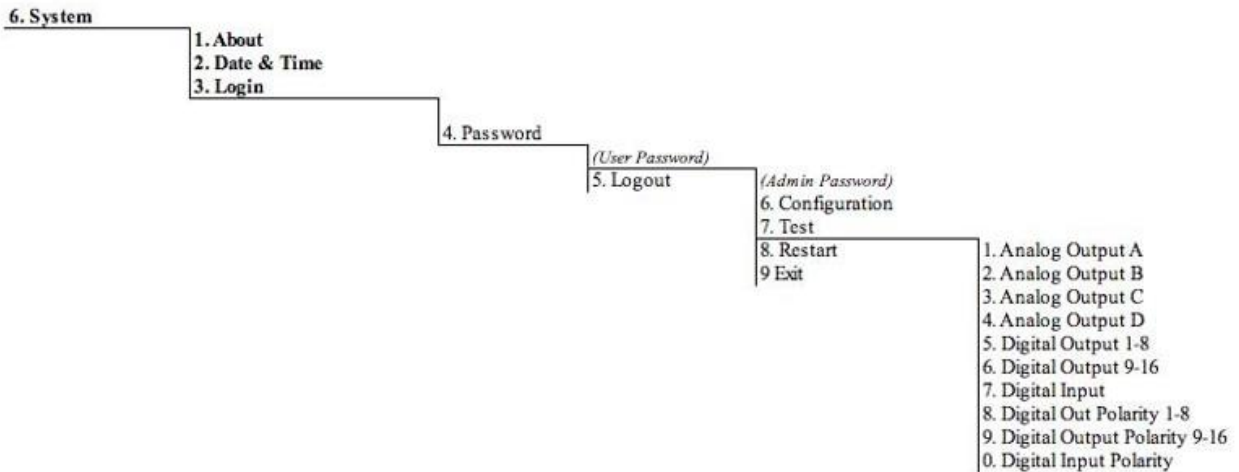

4-1D-2009 12:58		COSA 9610			
Wobbe	454.45	BTU/scf	Residual O2	18.34	mV
Calorific	345.55	BTU/scf	Spec Gravity	1.83	V
CARI	4.655		Power Supply	24.4	V
Spec Gravity	0.578		Sample	49.0	°C
Density	0.0466	lbs/cf	Oven	812.0	°C
Residual O2	9.56	%	Elec. Cabin	32.3	°C

System	
1 About	cal gas 1 high alarm
2 Date & time	cal gas 2 low alarm
3 Login	cal gas 3 calibrate
4 Password	range 1 validate
5 Logout	stream 1 range 2
6 Configuration	stream 2 cal fault
7 Test	valid 1 in op
8 Restart	valid 2 sys fault
9 Exit	watchdog --
	cal req --
	val req --
	stream sw --
	Admin access

Passwords:

- USER: 1234
- ADMIN: 9999

Display Menu

7. Display

1. Chart 1
2. Chart 2
3. Color

The screenshot shows the control panel display for the 9610CXc. At the top, it displays the date and time '4-10-2009 13:00' and the unit identifier 'COSA 9610'. The main display area is divided into two columns of data. The left column shows gas analysis parameters: Wobbe (454.46 BTU/scf), Calorific (345.56 BTU/scf), CARI (4.655), Spec Gravity (0.5782), Density (0.0466 lbs/cf), and Residual O2 (9.56 %). The right column shows temperature and voltage readings: Residual O2 (18.34 mV), Spec Gravity (1.83 V), Power Supply (24.4 V), Sample (49.0 °C), Oven (812.0 °C), and Elec. Cabin (32.3 °C). Below the data, there is a 'Display' menu with three options: '1 Chart 1', '2 Chart 2', and '3 Color'. To the right of the menu is a grid of status indicators for various components, including 'cal gas 1', 'cal gas 2', 'cal gas 3', 'range 1', 'range 2', 'stream 1', 'stream 2', 'valid 1', 'valid 2', 'watchdog', 'cal req', 'val req', and 'stream sw'. The 'valid 1' and 'in op' indicators are highlighted in yellow. At the bottom right, there is a yellow 'Admin access' button.

Parameter	Value	Unit
Wobbe	454.46	BTU/scf
Calorific	345.56	BTU/scf
CARI	4.655	
Spec Gravity	0.5782	
Density	0.0466	lbs/cf
Residual O2	9.56	%

Parameter	Value	Unit
Residual O2	18.34	mV
Spec Gravity	1.83	V
Power Supply	24.4	V
Sample	49.0	°C
Oven	812.0	°C
Elec. Cabin	32.3	°C

Menu Item	Status
cal gas 1	high alarm
cal gas 2	low alarm
cal gas 3	calibrate
range 1	validate
range 2	validate
stream 1	range 2
stream 2	cal fault
valid 1	in op
valid 2	sys fault
watchdog	---
cal req	---
val req	---
stream sw	---

Admin access

3.3.7. Reset Alarms Menu



3.4. TEMPERATURE CONTROLLED OVEN

3.4.1. Furnace temperature control unit

The zirconia cell must operate at a temperature above 600°C. For optimal performance, a set-point temperature of 812°C was chosen. The oven that serves as the heating device for the zirconia cell is made of a metal wire-wound heating element. To minimize energy consumption, the heating element is encapsulated by glass-fibre insulating material. The driving voltage for the heater is 120VAC. The power is controlled by computer.

The temperature controller utilizes a PID algorithm to drive a solid-state relay, which in its turn controls the on/off ratio of the voltage to the heater element, to generate alarms and to enable the system to compensate for temperature changes.

The oven temperature is controlled by software included in the operating system of the analyzer. All settings are factory programmed but may need to be fine-tuned depending on local conditions. However, for servicing purposes it can be useful to change the temperature of the oven. The temperature of the oven is displayed on the right-hand side of the display screen.

By accessing the Temperature menu is the measurement screen, one can increase the

temperature set-point. The oven needs about half an hour to heat up to 812°C. Normal on/off-ratio is about 85%. This allows for a stable temperature control and long lifetime of the oven (typically 2 – 8 years).

NOTE: Set oven temp to 812°C & sample system to 50°C for standard units, 90°C for mid-temp models

3.4.2. Adjustment procedure temperature regulator

This procedure describes the setting of the temperature controller. The controller measures the temperature with the help of a K-type thermocouple. The heating is arranged by a pulsing 5VDC signal. The on/off relation decides the added capacity. The tuning program in the regulator will optimize the regulator algorithm. This program decides the most optimal settings for the PID regulation.

Procedure:

- 1: Check the connections according to drawing.
- 2: Turn on the voltage.

4. PREVENTIVE MAINTENANCE

4.1. WEEKLY, MONTHLY, THREE (3) MONTH MAINTENANCE

4.1.1. Filters

Inspect three (3) filters, the pressure regulator air filter, gas filter, and coalescing filters, for signs of moisture, water, or liquids. If there is anything that indicate signs of moisture and/or liquids, these filters should be replaced.

Coalescing drain valve can be used to drain check for signs of liquids and remove them out of system.

All maintenance and install must be performed by trained personnel only.

! **Caution**

Before servicing any installed filter or strainer, must depressurize the system. The filter or strainer may contain residual system material.

4.2. ANNUAL MAINTENANCE

- Check the calibration gas bottles for pressure.
- Check the sample system for correct pressure.
- Check the bypass flow meter for correct flow rate.
- Replace the instrument air filters as required.
- Replace optional sample gas filters as required.
- Replace optional pump diaphragms as required.

4.3. TROUBLESHOOTING

Breakdown -> fault report	Test	Action
No air pressure -> flow alarm For Z-purge	tube fracture, leak in the system	Check for leak Replace tube
	Measuring pressure behind reducing valve (for z-purge)	Open valve for reducing valve tagged "air supply"
		Increase output pressure
No gas pressure -> flow alarm	Tube fracture	Close main valve immediately and replace pipe
	Blockage in gas supply	Check/clean/replace tubing
Oven temperature below 750°C -> temp low alarm	Check set point on temp. Controller. Check fuse 1 in TB1 of regulated supply	Reset
	Check fuse 4 in TB4 of temp. controller (display is off)	Replace
	Check output voltage temp. controller (0-5 VDC) to Solid State Relay	Contact supplier
	Check pulsating voltage (0-60 VAC) to oven	Contact supplier
	Check oven resistance $\pm 13 \Omega$	Contact supplier
Analyzer becomes slow > 20 seconds response time	Check system flows and gas pressures	Clean system and/or adjust to correct values
	Check resistance of cell, when sample gas is "shut off" it should be lower than 1000 Ω	Replace Zirconia cell
No response from analyzer	Response to mV signal on cell input terminals	Electronic problem. Check interface board or computer
	No mV signal from cell	Replace Zirconia cell
	Leak in mixing system	Check for leaks
	Response to mV signal on cell input terminals	Clean systems and/or adjust to correct values
No mA output signal	Check or the test value is set to "NO"	Set test value to "NO"
	Simulate mA signal wiring. Check test value on 0%, 25%, 50%, 75% and 100%	Contact supplier

4.4. REPLACEMENT OF RESIDUAL OXYGEN SENSOR AND CELL HOUSING

Before going any further make sure that the oven has been disconnected and cooled off so that no physical injury can occur caused by coming into contact with any parts which may still be hot.

1. Loosen the tube fittings nuts and disconnect 1/8" and 1/4" tubes from the fittings.

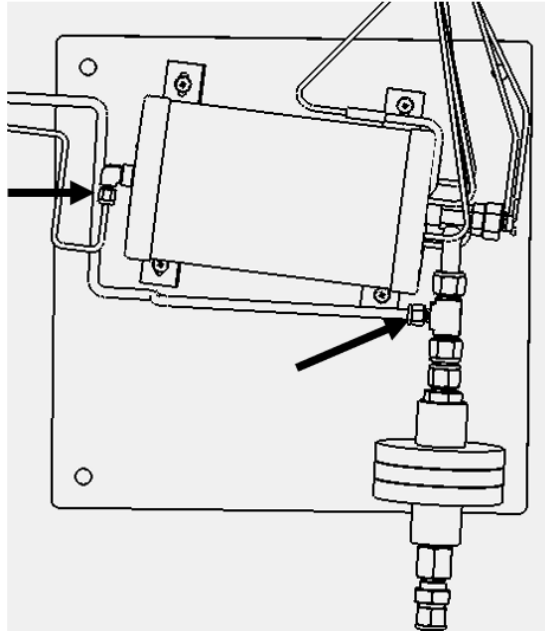

2. Disconnect the connecting clips from the oxygen sensor and remove the ceramic ring.

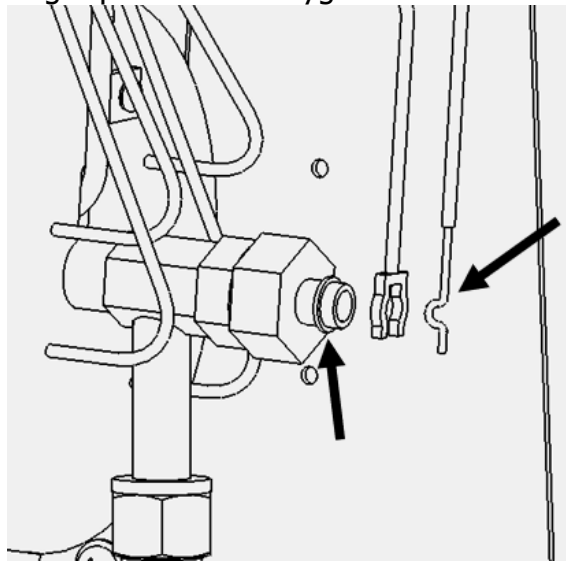

- Loosen $\frac{1}{2}$ " x $\frac{1}{2}$ " x $\frac{1}{4}$ " Reducing Union Tee and remove four (4) #10-32 screws.

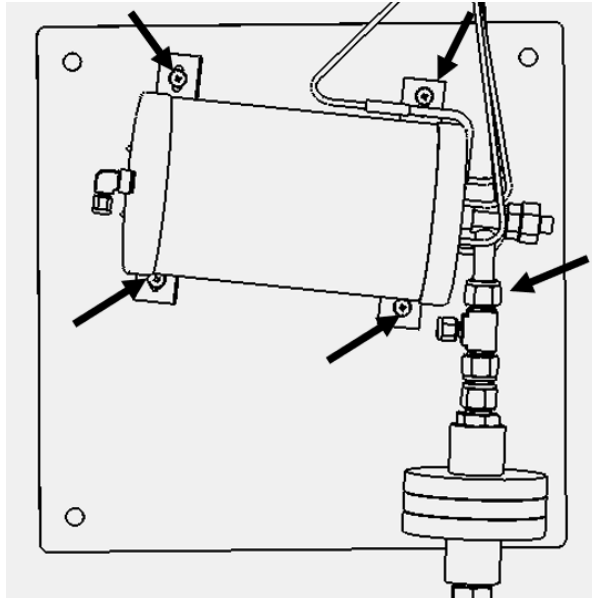

- Slowly remove the oven together with the thermal couple, cell housing, oxygen sensor, and wiring. Lay the oven down on the bottom of the oven compartment.

! Caution

Care must be taken as it may damage the wire connectors.

- Using $\frac{3}{4}$ " and 1" wrenches slowly break the oxygen sensor loose from the cell housing.

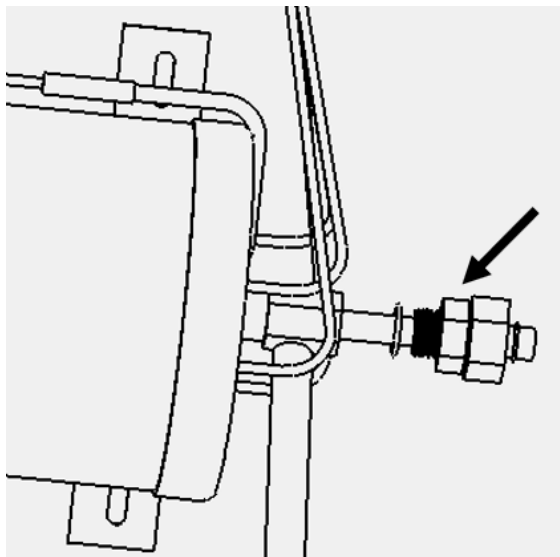

6. Remove the 1/8" T x 1/8" FNPT elbow fitting and then slide the cell housing out of the oven.

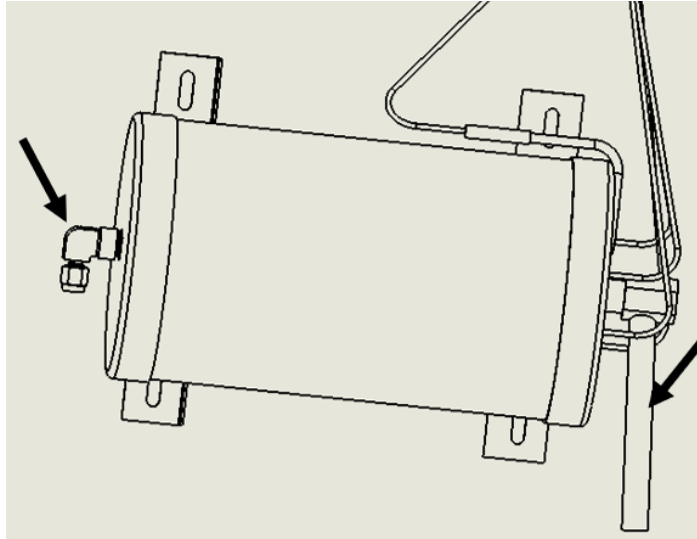

! **Caution**

O₂ sensor and cell housing may be melted together due to the excessive heat inside the oven. The new housing comes with a long 1/2" tube. It may need to trim off the length to fit in the assembly. Follow the below steps to replace the cell housing.

7. Install a new cell housing into the oven. Using four #10-32 screws to mount the oven assembly onto the oven compartment back plate.

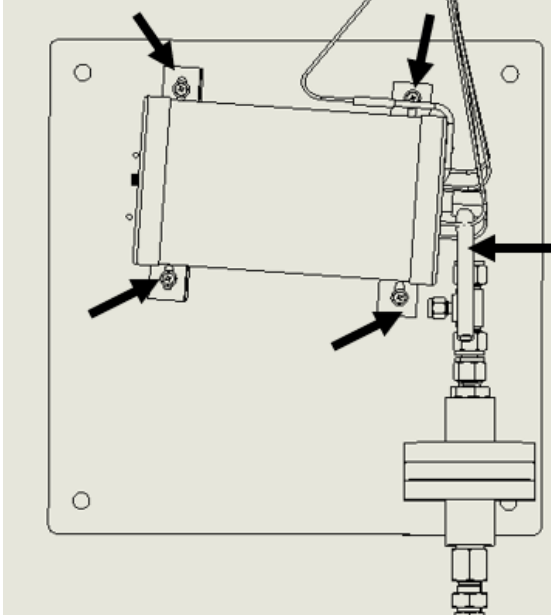

8. Mark the 1/2" tube at the internal shoulder of 1/2" x 1/2" x 1/4" Reducing Union Tee.

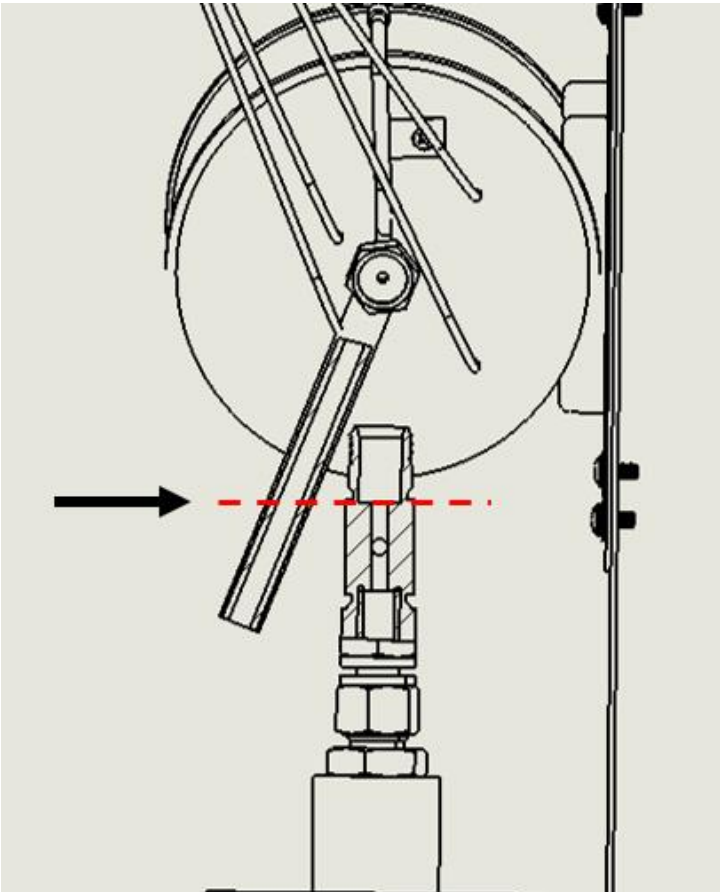

9. Remove the oven together with the cell housing from the oven compartment back plate. Remove the cell housing out of the oven. Use an appropriate cutting tool to trim off the 1/2" tube of the cell housing at the mark.

! Caution

Burrs created during the cutting process must be removed using the deburring tool or a file prior to assemble the cell housing.

10. Install the pre-cut cell housing back to the oven. Re-attached the 1/8" T x 1/8" FNPT elbow fitting to the other end of the cell housing.

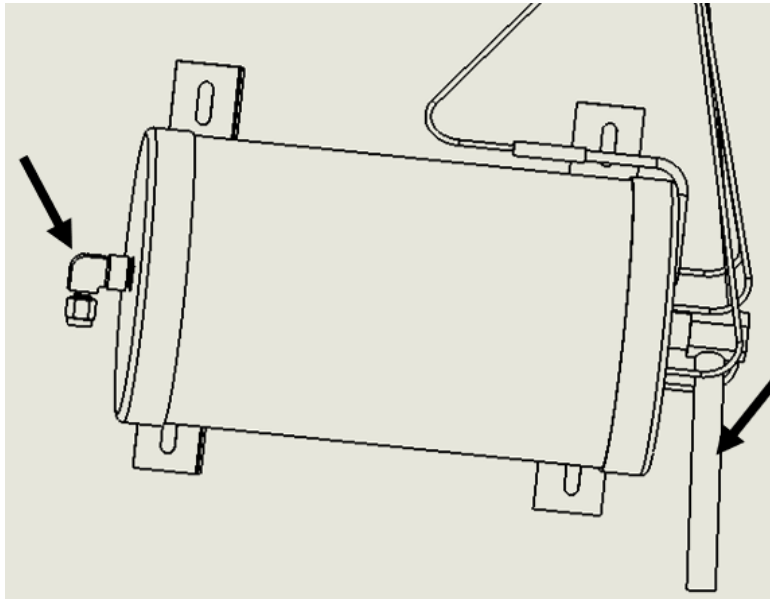

11. Install a new oxygen sensor together with a new metal seal to the sensor housing. Make sure the metal seal fully seat into the seal chamber of the cell housing. Carefully tighten the oxygen sensor to the cell housing.

! Caution

Care must be taken to make sure no dust, grease, or oil contact with the sensor.

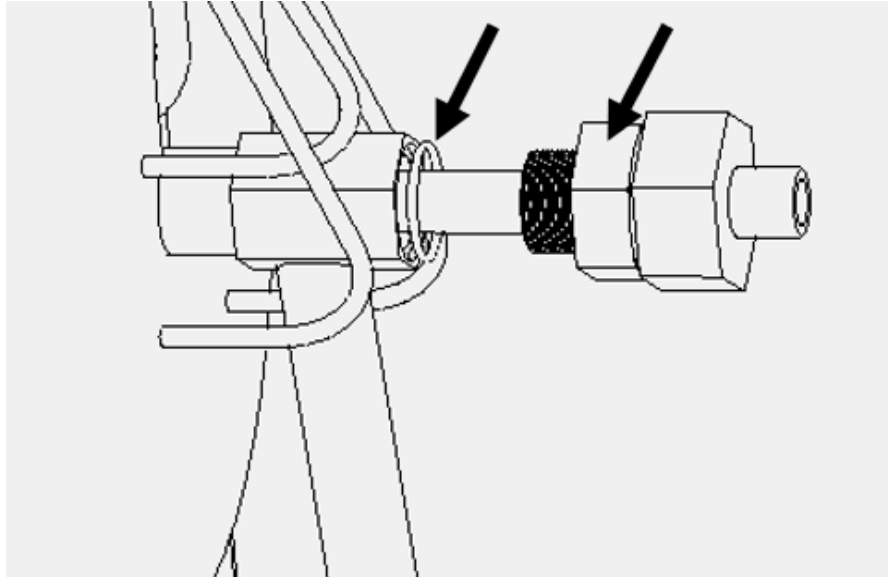

12. Continue to assemble the rest of components in the reverse order.

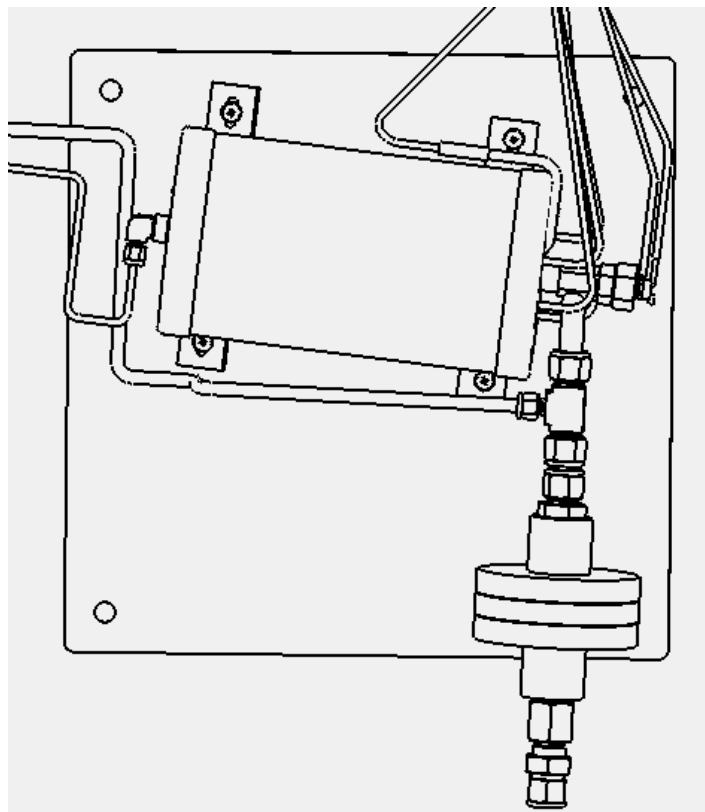

5. MODBUS REGISTER LIST

5.1. COIL REGISTERS

Register Number	Address	Access Level	Description
Physical output			
1	0 (0h)	User	Relay 1
2	1 (1h)	User	Relay 2
3	2 (2h)	User	Relay 3
4	3 (3h)	User	Relay 4
5	4 (4h)	User	Relay 5
6	5 (5h)	User	Relay 6
7	6 (6h)	User	Relay 7
8	7 (7h)	User	Relay 8
9	8 (8h)	User	Relay 9
10	9 (9h)	User	Relay 10
11	10 (Ah)	User	Relay 11
12	11 (Bh)	User	Relay 12
13	12 (Ch)	User	Relay 13
14	13 (Dh)	User	Relay 14
15	14 (Eh)	User	Relay 15
16	15 (Fh)	User	Relay 16
Logical input			
1001	1000 (3E8h)	User	Watchdog event status
1002	1001 (3E9h)	User	Calibration request
1003	1002 (3EAh)	User	Validation request
1004	1003 (3EBh)	User	Flow A alarm
1005	1004 (3ECh)	User	Flow B alarm
1006	1005 (3EDh)	User	Low process gas pressure alarm
1007	1006 (3EEh)	User	Low instrument air pressure alarm
1008	1007 (3EFh)	User	Low calibration gas pressure alarm
1009	1008 (3F0h)	User	Switch process stream control
1011	1010 (3F2h)	User	Abort calibration

5.2. DISCRETE INPUT REGISTERS

Register Number	Address	Access Level	Description
Physical input			
10001	0 (0h)	Read-Only	Digital input 1 state (watchdog event)
10002	1 (1h)	Read-Only	Digital input 2 state
10003	2 (2h)	Read-Only	Digital input 3 state
10004	3 (3h)	Read-Only	Digital input 4 state
10005	4 (4h)	Read-Only	Digital input 5 state
10006	5 (5h)	Read-Only	Digital input 6 state
10007	6 (6h)	Read-Only	Digital input 7 state
10008	7 (7h)	Read-Only	Digital input 8 state
Logical input			
11001	1000 (3E8h)	Read-Only	Watchdog event status
11002	1001 (3E9h)	Read-Only	Calibration request
11003	1002 (3EAh)	Read-Only	Validation request
11004	1003 (3EBh)	Read-Only	Flow A alarm
11005	1004 (3ECh)	Read-Only	Flow B alarm
11006	1005 (3EDh)	Read-Only	Low process gas pressure alarm
11007	1006 (3EEh)	Read-Only	Low instrument air pressure alarm
11008	1007 (3EFh)	Read-Only	Low calibration gas pressure alarm
11009	1008 (3F0h)	Read-Only	Switch process stream control
11011	1010 (3F2h)	Read-Only	Abort calibration
Logical output			
11101	1100 (44Ch)	Read-Only	Calibration gas 1 relay
11102	1101 (44Dh)	Read-Only	Calibration gas 2 relay
11103	1102 (44Eh)	Read-Only	Calibration gas 3 relay
11104	1103 (44Fh)	Read-Only	Range 1 relay
11105	1104 (450h)	Read-Only	Process stream 1 relay
11106	1105 (451h)	Read-Only	Process stream 2 relay
11107	1106 (452h)	Read-Only	Process stream 3 relay
11108	1107 (453h)	Read-Only	Process stream 4 relay
11109	1108 (454h)	Read-Only	Valid stream 1 relay
11110	1109 (455h)	Read-Only	Valid stream 2 relay
11111	1110 (456h)	Read-Only	Valid stream 3 relay
11112	1111 (457h)	Read-Only	Valid stream 4 relay
11113	1112 (458h)	Read-Only	High gas alarm relay
11114	1113 (459h)	Read-Only	Low gas alarm relay
11115	1114 (45Ah)	Read-Only	In calibration status relay
11116	1115 (45Bh)	Read-Only	In validation status relay
11117	1116 (45Ch)	Read-Only	Range 2 relay
11118	1117 (45Dh)	Read-Only	Stream select bit 0 relay
11119	1118 (45Eh)	Read-Only	Stream select bit 1 relay
11120	1119 (45Fh)	Read-Only	System fault status relay
11121	1120 (460h)	Read-Only	Watchdog fault status relay
11122	1121 (461h)	Read-Only	In operation status relay
11123	1122 (462h)	Read-Only	Calibration fault status relay

Register Number	Address	Access Level	Description
11124	1123 (463h)	Read-Only	Pressure gas status relay
11125	1124 (464h)	Read-Only	Pressure air status relay
11126	1125 (465h)	Read-Only	Pressure calibration gas status relay

5.3. INPUT REGISTERS

Register Number	Address	Access Level	Data Type	Description
30001	0 (0h)	Read-Only	Float	Wobbe index
30003	2 (2h)	Read-Only	Float	Calorific value
30005	4 (4h)	Read-Only	Float	CARI
30007	6 (6h)	Read-Only	Float	Specific gravity
30009	8 (8h)	Read-Only	Float	Density
30011	10 (Ah)	Read-Only	Float	Residual oxygen %
30013	12 (Ch)	Read-Only	Float	Sample temperature
30015	14 (Eh)	Read-Only	Float	Oven temperature
30017	16 (10h)	Read-Only	Float	Oven inlet temperature
30019	18 (12h)	Read-Only	Float	Oven outlet temperature
30021	20 (14h)	Read-Only	Float	Electrical cabin temperature
30023	22 (16h)	Read-Only	Float	Power supply voltage
30029	28 (1Ch)	Read-Only	Float	Residual oxygen mV
30031	30 (1Eh)	Read-Only	Float	Specific gravity V
30037	36 (24h)	Read-Only	Float	Stream 1 Wobbe index
30039	38 (26h)	Read-Only	Float	Stream 2 Wobbe index
30045	44 (2Ch)	Read-Only	Float	Stream 1 Calorific value
30047	46 (2Eh)	Read-Only	Float	Stream 2 Calorific value
30053	52 (34h)	Read-Only	Float	Stream 1 CARI
30055	54 (36h)	Read-Only	Float	Stream 2 CARI
30061	60 (3Ch)	Read-Only	Float	Stream 1 specific gravity
30063	62 (3Eh)	Read-Only	Float	Stream 2 specific gravity
30069	68 (44h)	Read-Only	Float	Stream 1 density
30071	70 (46h)	Read-Only	Float	Stream 2 density
30077	76 (4Ch)	Read-Only	Float	Stream 1 residual oxygen %
30079	78 (4Eh)	Read-Only	Float	Stream 2 residual oxygen %

5.4. HOLDING REGISTERS

Register Number	Address	Access Level	Data Type	Description	Values
Measurement setting registers					
40101	100 (64h)	User	16-bit	Wobbe index engineering unit	0=MJ/Nm ³ 1=kcal/Nm ³ 2=BTU/scf 3=MJ/Sm ³
40106	105 (69h)	Admin	Float	Wobbe index low alarm	
40108	107 (6Bh)	Admin	Float	Wobbe index high alarm	
40110	109 (6Dh)	User	16-bit	Calorific value engineering unit	0=MJ/Nm ³ 1=kcal/Nm ³ 2=BTU/scf 3=MJ/Sm ³ 4=kJ/kg 5=MJ/kg 6=kcal/kg 7=BTU/lbs
40115	114 (72h)	Admin	Float	Calorific value low alarm	
40117	116 (74h)	Admin	Float	Calorific value high alarm	
40124	123 (7Bh)	Admin	Float	CARI low alarm	
40126	125 (7Dh)	Admin	Float	CARI high alarm	
40133	132 (84h)	Admin	Float	Specific gravity low alarm	
40135	134 (86h)	Admin	Float	Specific gravity high alarm	
40137	136 (88h)	User	16-bit	Density engineering unit	0=kg/NM ³ 1=lbs/cf
40142	141 (8Dh)	Admin	Float	Density low alarm	
40144	143 (8Fh)	Admin	Float	Density high alarm	
40151	150 (96h)	Admin	Float	Residual Oxygen % low alarm	
40153	152 (98h)	Admin	Float	Residual Oxygen % high alarm	
40160	159 (9Fh)	Admin	Float	Sample temperature low alarm	
40162	161 (A1h)	Admin	Float	Sample temperature high alarm	
40169	168 (A8h)	Admin	Float	Oven temperature low alarm	
40171	170 (AAh)	Admin	Float	Oven temperature high alarm	
40178	177 (B1h)	Admin	Float	Oven inlet temperature low alarm	

INSTALLATION, OPERATION AND MAINTENANCE MANUAL – 9610CXc™

Register Number	Address	Access Level	Data Type	Description	Values
40180	179 (B3h)	Admin	Float	Oven inlet temperature high alarm	
40187	186 (BAh)	Admin	Float	Oven outlet temperature low alarm	
40189	188 (BCh)	Admin	Float	Oven outlet temperature high alarm	
40196	195 (C3h)	Admin	Float	Electrical cabin temperature low alarm	
40198	197 (C5h)	Admin	Float	Electrical cabin temperature high alarm	
40205	204 (CCh)	Admin	Float	Power supply voltage low alarm	
40207	206 (CEh)	Admin	Float	Power supply voltage high alarm	
40232	231 (E7h)	Admin	Float	Residual oxygen mV low alarm	
40234	233 (E9h)	Admin	Float	Residual oxygen mV high alarm	
40241	240 (F0h)	Admin	Float	Specific gravity voltage low alarm	
40243	242 (F2h)	Admin	Float	Specific gravity voltage high alarm	
Digital output registers					
40305	304 (130h)	Admin	16-bit	Digital output 1 mode	Bit 0=polarity 0=active low 1=active high Bit 1-6=variable 0=Off 1=calibration gas 1 valve 2=calibration gas 2 valve 3=calibration gas 3 valve 4=dual range selection valve 5=process stream 1 valve 6=process stream 2 valve 7=process stream 3 valve 8=process stream 4 valve 9=valid analog output 1 status 10=valid analog output 2 status 11=valid analog output 3 status 12=valid analog output 4 status 13=high alarm error 14=low alarm error 15=in calibration 16=in validation 17=dual range selection status
40306	305 (131h)	Admin	16-bit	Digital output 2 mode	
40307	306 (132h)	Admin	16-bit	Digital output 3 mode	
40308	307 (133h)	Admin	16-bit	Digital output 4 mode	
40309	308 (134h)	Admin	16-bit	Digital output 5 mode	
40310	309 (135h)	Admin	16-bit	Digital output 6 mode	
40311	310 (136h)	Admin	16-bit	Digital output 7 mode	
40312	311 (137h)	Admin	16-bit	Digital output 8 mode	
40313	312 (138h)	Admin	16-bit	Digital output 9 mode	
40314	313 (139h)	Admin	16-bit	Digital output 10 mode	
40315	314 (13Ah)	Admin	16-bit	Digital output 11 mode	
40316	315 (13Bh)	Admin	16-bit	Digital output 12 mode	

INSTALLATION, OPERATION AND MAINTENANCE MANUAL – 9610CXc™

Register Number	Address	Access Level	Data Type	Description	Values
40317	316 (13Ch)	Admin	16-bit	Digital output 13 mode	18=stream select status bit 0 19=stream select status bit 1 20=system fault 21=watchdog pulse 22=in operation 23=calibration error 24=low process gas pressure 25=low instrument air pressure 26=low calibration gas pressure
40318	317 (13Dh)	Admin	16-bit	Digital output 14 mode	
40319	318 (13Eh)	Admin	16-bit	Digital output 15 mode	
40320	319 (13Fh)	Admin	16-bit	Digital output 16 mode	
Digital input registers					
40351	350 (15Eh)	Admin	16-bit	Digital input 1 mode	Bit 0=polarity 0=active low 1=active high Bit 1-6=variable 0=Off 1=watchdog event 2=calibration request 3=validation request 4=flow A alarm 5=flow B alarm 6=low process gas alarm 7=low instrument air alarm 8=low calibration gas alarm 9=switch process stream 11=abort calibration/validation
40352	351 (15Fh)	Admin	16-bit	Digital input 2 mode	
40353	352 (160h)	Admin	16-bit	Digital input 3 mode	
40354	353 (161h)	Admin	16-bit	Digital input 4 mode	
40355	354 (162h)	Admin	16-bit	Digital input 5 mode	
40356	355 (163h)	Admin	16-bit	Digital input 6 mode	
40357	356 (164h)	Admin	16-bit	Digital input 7 mode	
40358	357 (165h)	Admin	16-bit	Digital input 8 mode	
Analog output registers					
40402	401 (191h)	Admin	16-bit	Output A 4mA DAC value	Valid values are 0-4095
40403	402 (192h)	Admin	16-bit	Output A 20mA DAC value	Valid values are 0-4095
40405	404 (194h)	Admin	16-bit	Output A variable	See variable list
40406	405 (195h)	Admin	Float	Output A low limit	Lower limit of the measurement output range If output variable is off, output value = Low Limit / High Limit x 100%
40408	407 (197h)	Admin	Float	Output A high limit	Upper limit of the measurement output range If output variable is off, output value = Low Limit / High Limit x 100%

Register Number	Address	Access Level	Data Type	Description	Values
40412	411 (19Bh)	Admin	16-bit	Output B 4mA DAC value	Valid values are 0-4095
40413	412 (19Ch)	Admin	16-bit	Output B 20mA DAC value	Valid values are 0-4095
40415	414 (19Eh)	Admin	16-bit	Output B variable	See variable list
40416	415 (19Fh)	Admin	Float	Output B low limit	Lower limit of the measurement output range If output variable is off, output value = Low Limit / High Limit x 100%
40418	417 (1A1h)	Admin	Float	Output B high limit	Upper limit of the measurement output range If output variable is off, output value = Low Limit / High Limit x 100%
40422	421 (1A5h)	Admin	16-bit	Output C 4mA DAC value	Valid values are 0-4095
40423	422 (1A6h)	Admin	16-bit	Output C 20mA DAC value	Valid values are 0-4095
40425	424 (1A8h)	Admin	16-bit	Output C variable	See variable list
40426	425 (1A9h)	Admin	Float	Output C low limit	Lower limit of the measurement output range If output variable is off, output value = Low Limit / High Limit x 100%
40428	427 (1ABh)	Admin	Float	Output C high limit	Upper limit of the measurement output range If output variable is off, output value = Low Limit / High Limit x 100%
40432	431 (1AFh)	Admin	16-bit	Output D 4mA DAC value	Valid values are 0-4095
40433	432 (1B0h)	Admin	16-bit	Output D 20mA DAC value	Valid values are 0-4095
40435	434 (1B2h)	Admin	16-bit	Output D variable	See variable list
40436	435 (1B3h)	Admin	Float	Output D low limit	Lower limit of the measurement output range If output variable is off, output value = Low Limit / High Limit x 100%
40438	437 (1B5h)	Admin	Float	Output D high limit	Upper limit of the measurement output range If output variable is off, output value = Low Limit / High Limit x 100%
Analog input registers					
40502	501 (1F5h)	Admin	16-bit	Residual oxygen averaging buffer size in sec	Valid values are 0-60
40508	507 (1FBh)	Admin	16-bit	Oven temperature averaging buffer size in sec	Valid values are 0-60
40514	513 (201h)	Admin	16-bit	Specific gravity averaging buffer size in sec	Valid values are 0-60
40520	519 (207h)	Admin	16-bit	Electrical cabin temperature averaging buffer size in sec	Valid values are 0-60
40526	525 (20Dh)	Admin	16-bit	Power supply voltage averaging buffer size in sec	Valid values are 0-60
40532	531 (213h)	Admin	16-bit	Oven inlet temperature averaging buffer size in sec	Valid values are 0-60

Register Number	Address	Access Level	Data Type	Description	Values
40538	537 (219h)	Admin	16-bit	Oven outlet temperature averaging buffer size in sec	Valid values are 0-60
40544	543 (21Fh)	Admin	16-bit	Sample temperature averaging buffer size in sec	Valid values are 0-60
Serial Link Registers					
40603	602 (25Ah)	User	16-bit	Serial port baud rate	0=300 baud 1=600 baud 2=1,200 baud 3=2,400 baud 4=4,800 baud 5=9,600 baud 6=19,200 baud 7=38,400 baud 8=57,600 baud 9=115,200 baud
40604	603 (25Bh)	User	16-bit	Serial port parity	0=No parity 1=Odd parity 2=Even parity
40605	604 (25Ch)	User	16-bit	Serial message timeout in msec	Valid values are 1-60,000
Display Registers					
40804	803 (323h)	User	16-bit	Font type	16-bit RGB code
40805	804 (324h)	User	16-bit	Text color	16-bit RGB code
40806	805 (325h)	User	16-bit	Active text color	16-bit RGB code
40807	806 (326h)	User	16-bit	Inactive text color	16-bit RGB code
40808	807 (327h)	User	16-bit	Border color	16-bit RGB code
40809	808 (328h)	User	16-bit	Background color	16-bit RGB code
40810	809 (329h)	User	16-bit	Highlight color	16-bit RGB code
40811	810 (32Ah)	User	16-bit	Title color	16-bit RGB code
40812	811 (32Bh)	User	16-bit	Selected text color	16-bit RGB code
40813	812 (32Ch)	User	16-bit	Active Field color	16-bit RGB code
40814	813 (32Dh)	User	16-bit	Inactive field color	16-bit RGB code
Chart Registers					
40842	841 (349h)	User	16-bit	Top chart update rate in msec	Valid values are 1-60,000
40844	843 (34Bh)	User	16-bit	Top chart variable	See variable list
40845	844 (34Ch)	User	Float	Top chart y-axis minimum value	
40847	846 (34Eh)	User	Float	Top chart y-axis maximum value	

INSTALLATION, OPERATION AND MAINTENANCE MANUAL – 9610CXc™

Register Number	Address	Access Level	Data Type	Description	Values
40849	848 (350h)	User	16-bit	Number of steps on top chart y-axis	Valid values are 1-10
40857	856 (358h)	User	16-bit	Bottom chart update rate in msec	Valid values are 1-60,000
40859	858 (35Ah)	User	16-bit	Bottom chart variable	See variable list
40860	859 (35Bh)	User	Float	Bottom chart y-axis minimum value	
40862	861 (35Dh)	User	Float	Bottom chart y-axis maximum value	
40864	863 (35Fh)	User	16-bit	Number of steps on bottom chart y-axis	Valid values are 1-10
System Registers					
41008	1007 (3EFh)	User	16-bit	Date format	0=mm/dd/yyyy 1=dd/mm/yyyy
41009	1008 (3F0h)	User	16-bit	Time format	0=24 hour format 1=12 hour format
41010	1009 (3F1h)	User	16-bit	Word order	0=Lower word first 1=Upper word first
41011	1010 (3F2h)	Read-Only	16-bit	Model number	
41012	1011 (3F3h)	Read-Only	32-bit	Serial number	
41014	1013 (3F5h)	Read-Only	32-bit	Software revision	
41016	1015 (3F7h)	Read-Only	16-bit	Available options	
41021	1020 (3FCh)	User	16-bit	Access request	0=Locked mode 1=User level 2=Administrator level 3=Calibrator level 4=Factory configuration level 129=Change user password 130=Change administrator password
41022	1021 (3FDh)	Admin	String	Password	Up to 10 characters. Only bits 0-7 on each register are used for a character.
Device Specific Registers					
41501	1500 (5DCh)	User	16-bit	Operation delay in sec	Valid values are 0-3600
41502	1501 (5DDh)	User	16-bit	Warm-up delay in sec	Valid values are 0-3600
41503	1502 (5DEh)	Admin	Float	Process pressure	Valid values are 0-10.0
41505	1504 (5E0h)	Admin	Float	H2 factor A	
41507	1506 (5E2h)	Admin	Float	H2 factor B	
41509	1508 (5E4h)	Admin	16-bit	Residual oxygen averaging buffer size during calibration in sec	Valid values are 0-60

INSTALLATION, OPERATION AND MAINTENANCE MANUAL – 9610CXc™

Register Number	Address	Access Level	Data Type	Description	Values
41510	1509 (5E5h)	Admin	Float	Oven temperature setpoint in °C	
41512	1511 (5E7h)	Admin	16-bit	Oven temperature adjustment enable	0=Disable 1=Enable
41513	1512 (5E8h)	Admin	Float	Wobbe index calibration coefficient 0	
41515	1514 (5EAh)	Admin	Float	Wobbe index calibration coefficient 1	
41517	1516 (5ECh)	Admin	Float	Wobbe index calibration coefficient 2	
41519	1518 (5EEh)	Admin	Float	Wobbe index calibration coefficient 3	
41521	1520 (5F0h)	Admin	Float	High range Wobbe index calibration coefficient 0	
41523	1522 (5F2h)	Admin	Float	High range Wobbe index calibration coefficient 1	
41525	1524 (5F4h)	Admin	Float	High range Wobbe index calibration coefficient 2	
41527	1526 (5F6h)	Admin	Float	High range Wobbe index calibration coefficient 3	
41529	1528 (5F8h)	Admin	Float	Wobbe index correction coefficient 0	
41531	1530 (5FAh)	Admin	Float	Wobbe index correction coefficient 1	
41533	1532 (5FCh)	Admin	Float	Wobbe index correction coefficient 2	
41535	1534 (5FEh)	Admin	Float	Wobbe index correction coefficient 3	
41537	1536 (600h)	Admin	Float	CARI calibration coefficient 0	
41539	1538 (602h)	Admin	Float	CARI calibration coefficient 1	
41541	1540 (604h)	Admin	Float	CARI calibration coefficient 2	
41543	1542 (606h)	Admin	Float	CARI calibration coefficient 3	
41545	1544 (608h)	Admin	Float	High range CARI calibration coefficient 0	
41547	1546 (60Ah)	Admin	Float	High range CARI calibration coefficient 1	
41549	1548 (60Ch)	Admin	Float	High range CARI calibration coefficient 2	
41551	1550 (60Eh)	Admin	Float	High range CARI calibration coefficient 3	
41553	1552 (610h)	Admin	Float	Specific gravity low calibration point	
41555	1554 (612h)	Admin	Float	Specific gravity high calibration point	
41557	1556 (614h)	Admin	Float	Voltage of specific gravity low calibration point	
41559	1558 (616h)	Admin	Float	Voltage of specific gravity high calibration point	
41561	1560 (618h)	Admin	Float	Specific gravity factor	
41563	1562 (61Ah)	User	16-bit	Automatic calibration mode	0=Disable 1=1-point calibration 2=2-point calibration 3=Dual range calibration

INSTALLATION, OPERATION AND MAINTENANCE MANUAL – 9610CXc™

Register Number	Address	Access Level	Data Type	Description	Values
41564	1563 (61Bh)	User	16-bit	Timed calibration mode	0=Disable 1=1-point calibration 2=2-point calibration 3=Dual range calibration
41565	1564 (61Ch)	User	16-bit	Timed calibration method	0=Repeat periodically 1=Weekly schedule
41566	1565 (61Dh)	User	16-bit	Year of next calibration date	Valid values are 2008-9999
41567	1566 (61Eh)	User	16-bit	Month of next calibration date	Valid values are 1-12
41568	1567 (61Fh)	User	16-bit	Day of next calibration date	Valid values are 1-31
41569	1568 (620h)	User	16-bit	Hour of next calibration time	Valid values are 0-23
41570	1569 (621h)	User	16-bit	Minute of next calibration time	Valid values are 0-59
41571	1570 (622h)	User	16-bit	Next calibration operation	0=Validation 1=Calibration
41572	1571 (623h)	User	16-bit	Timed calibration period in hours	
41573	1572 (624h)	User	16-bit	Sunday calibration time 1	Value=hour x 100 + minute Example: 2:15pm = 1415
41574	1573 (625h)	User	16-bit	Sunday calibration 1 operation	0=Validation 1=Calibration
41575	1574 (626h)	User	16-bit	Sunday calibration time 2	Value=hour x 100 + minute Example: 2:15pm = 1415
41576	1575 (627h)	User	16-bit	Sunday calibration 2 operation	0=Validation 1=Calibration
41577	1576 (628h)	User	16-bit	Sunday calibration time 3	Value=hour x 100 + minute Example: 2:15pm = 1415
41578	1577 (629h)	User	16-bit	Sunday calibration 3 operation	0=Validation 1=Calibration
41579	1578 (62Ah)	User	16-bit	Monday calibration time 1	Value=hour x 100 + minute Example: 2:15pm = 1415
41580	1579 (62Bh)	User	16-bit	Monday calibration 1 operation	0=Validation 1=Calibration
41581	1580 (62Ch)	User	16-bit	Monday calibration time 2	Value=hour x 100 + minute Example: 2:15pm = 1415
41582	1581 (62Dh)	User	16-bit	Monday calibration 2 operation	0=Validation 1=Calibration

INSTALLATION, OPERATION AND MAINTENANCE MANUAL – 9610CXc™

Register Number	Address	Access Level	Data Type	Description	Values
41583	1582 (62Eh)	User	16-bit	Monday calibration time 3	Value=hour x 100 + minute Example: 2:15pm = 1415
41584	1583 (62Fh)	User	16-bit	Monday calibration 3 operation	0=Validation 1=Calibration
41585	1584 (630h)	User	16-bit	Tuesday calibration time 1	Value=hour x 100 + minute Example: 2:15pm = 1415
41586	1585 (631h)	User	16-bit	Tuesday calibration 1 operation	0=Validation 1=Calibration
41587	1586 (632h)	User	16-bit	Tuesday calibration time 2	Value=hour x 100 + minute Example: 2:15pm = 1415
41588	1587 (633h)	User	16-bit	Tuesday calibration 2 operation	0=Validation 1=Calibration
41589	1588 (634h)	User	16-bit	Tuesday calibration time 3	Value=hour x 100 + minute Example: 2:15pm = 1415
41590	1589 (635h)	User	16-bit	Tuesday calibration 3 operation	0=Validation 1=Calibration
41591	1590 (636h)	User	16-bit	Wednesday calibration time 1	Value=hour x 100 + minute Example: 2:15pm = 1415
41592	1591 (637h)	User	16-bit	Wednesday calibration 1 operation	0=Validation 1=Calibration
41593	1592 (638h)	User	16-bit	Wednesday calibration time 2	Value=hour x 100 + minute Example: 2:15pm = 1415
41594	1593 (639h)	User	16-bit	Wednesday calibration 2 operation	0=Validation 1=Calibration
41595	1594 (63Ah)	User	16-bit	Wednesday calibration time 3	Value=hour x 100 + minute Example: 2:15pm = 1415
41596	1595 (63Bh)	User	16-bit	Wednesday calibration 3 operation	0=Validation 1=Calibration
41597	1596 (63Ch)	User	16-bit	Thursday calibration time 1	Value=hour x 100 + minute Example: 2:15pm = 1415
41598	1597 (63Dh)	User	16-bit	Thursday calibration 1 operation	0=Validation 1=Calibration
41599	1598 (63Eh)	User	16-bit	Thursday calibration time 2	Value=hour x 100 + minute Example: 2:15pm = 1415

INSTALLATION, OPERATION AND MAINTENANCE MANUAL – 9610CXc™

Register Number	Address	Access Level	Data Type	Description	Values
41600	1599 (63Fh)	User	16-bit	Thursday calibration 2 operation	0=Validation 1=Calibration
41601	1600 (640h)	User	16-bit	Thursday calibration time 3	Value=hour x 100 + minute Example: 2:15pm = 1415
41602	1601 (641h)	User	16-bit	Thursday calibration 3 operation	0=Validation 1=Calibration
41603	1602 (642h)	User	16-bit	Friday calibration time 1	Value=hour x 100 + minute Example: 2:15pm = 1415
41604	1603 (643h)	User	16-bit	Friday calibration 1 operation	0=Validation 1=Calibration
41605	1604 (644h)	User	16-bit	Friday calibration time 2	Value=hour x 100 + minute Example: 2:15pm = 1415
41606	1605 (645h)	User	16-bit	Friday calibration 2 operation	0=Validation 1=Calibration
41607	1606 (646h)	User	16-bit	Friday calibration time 3	Value=hour x 100 + minute Example: 2:15pm = 1415
41608	1607 (647h)	User	16-bit	Friday calibration 3 operation	0=Validation 1=Calibration
41609	1608 (648h)	User	16-bit	Saturday calibration time 1	Value=hour x 100 + minute Example: 2:15pm = 1415
41610	1609 (649h)	User	16-bit	Saturday calibration 1 operation	0=Validation 1=Calibration
41611	1610 (64Ah)	User	16-bit	Saturday calibration time 2	Value=hour x 100 + minute Example: 2:15pm = 1415
41612	1611 (64Bh)	User	16-bit	Saturday calibration 2 operation	0=Validation 1=Calibration
41613	1612 (64Ch)	User	16-bit	Saturday calibration time 3	Value=hour x 100 + minute Example: 2:15pm = 1415
41614	1613 (64Dh)	User	16-bit	Saturday calibration 3 operation	0=Validation 1=Calibration
41615	1614 (64Eh)	User	16-bit	Remote calibration mode	0=Disable 1=1-point calibration 2=2-point calibration 3=Dual range calibration
41616	1615 (64Fh)	User	16-bit	Calibration gas switch time in sec	Valid values are 10-600

INSTALLATION, OPERATION AND MAINTENANCE MANUAL – 9610CXc™

Register Number	Address	Access Level	Data Type	Description	Values
41617	1616 (650h)	User	16-bit	Calibration start delay in sec	Valid values are 0-600
41618	1617 (651h)	User	16-bit	Output A operation during calibration	0=0/4mA 1=Hold 2=Track
41619	1618 (652h)	User	16-bit	Output B operation during calibration	0=0/4mA 1=Hold 2=Track
41620	1619 (653h)	User	16-bit	Output C operation during calibration	0=0/4mA 1=Hold 2=Track
41621	1620 (654h)	User	16-bit	Output D operation during calibration	0=0/4mA 1=Hold 2=Track
41622	1621 (655h)	User	Float	Calibration gas 1 Wobbe index	
41624	1623 (657h)	User	Float	Calibration gas 2 Wobbe index	
41626	1625 (659h)	User	Float	Calibration gas 3 Wobbe index	
41628	1627 (65Bh)	User	Float	Calibration gas 1 CARI	
41630	1629 (65Dh)	User	Float	Calibration gas 2 CARI	
41632	1631 (65Fh)	User	Float	Calibration gas 3 CARI	
41634	1633 (661h)	User	Float	Calibration gas 1 specific gravity	
41636	1635 (663h)	User	Float	Calibration gas 2 specific gravity	
41638	1637 (665h)	User	16-bit	Calibration error detection method	0=Disable 1=Percentage 2=Value
41639	1638 (666h)	User	16-bit	Calibration error percentage in 0.1% resolution	
41640	1639 (667h)	User	16-bit	Calibration error value in 0.1 resolution	
41641	1640 (668h)	User	16-bit	Dual range system enable	0=Disable 1=Enable
41642	1641 (669h)	Admin	Float	Dual range oxygen flip above threshold in mV	
41644	1643 (66Bh)	Admin	Float	Dual range oxygen flop below threshold in mV	
41646	1645 (66Dh)	User	16-bit	Dual range switch hold time	Valid values are 0-60
41647	1646 (66Eh)	User	Float	Dual range positive hysteresis in mV	
41649	1648 (670h)	User	Float	Dual range negative hysteresis in mV	

Register Number	Address	Access Level	Data Type	Description	Values
41651	1650 (672h)	User	16-bit	Multi-stream mode	0=Disable 1=Remote 2=Continuous 3=Timer
41652	1651 (673h)	User	16-bit	Number of input streams	Valid values are 1-4
41653	1652 (674h)	User	16-bit	Active process stream in continuous stream mode	Valid values are 1-4
41654	1653 (675h)	User	16-bit	Delay for multi-stream switching in sec	Valid values are 1-600
41655	1654 (676h)	User	16-bit	Measuring time for stream 1	Valid values are 1-3600
41656	1655 (677h)	User	16-bit	Measuring time for stream 2	Valid values are 1-3600
41657	1656 (678h)	User	16-bit	Measuring time for stream 3	Valid values are 1-3600
41658	1657 (679h)	User	16-bit	Measuring time for stream 4	Valid values are 1-3600
41659	1658 (67Ah)	User	Float	Sample system temperature setpoint in °C	

5.4. VARIABLE LIST

Variable	Analog output variable	Chart Y-axis variable
Off	0	N/A
Wobbe index	1	0
Calorific value	2	1
CARI	3	2
Specific gravity	4	3
Density	5	4
Residual oxygen %	6	5
Sample temperature	7	6
Oven temperature	8	7
Oven inlet temperature	9	8
Oven outlet temperature	10	9
Electrical cabin temperature	11	10
Power supply voltage	12	11
Residual oxygen mV	15	14
Specific gravity voltage	16	15
Stream 1 Wobbe index	19	18
Stream 2 Wobbe index	20	19
Stream 1 Calorific value	23	22
Stream 2 Calorific value	24	23
Stream 1 CARI	27	26
Stream 2 CARI	28	27
Stream 1 specific gravity	31	30
Stream 2 specific gravity	32	31
Stream 1 density	35	34
Stream 2 density	36	35
Stream 1 residual oxygen %	39	38
Stream 2 residual oxygen %	40	39

6. INSTALLATION DRAWING

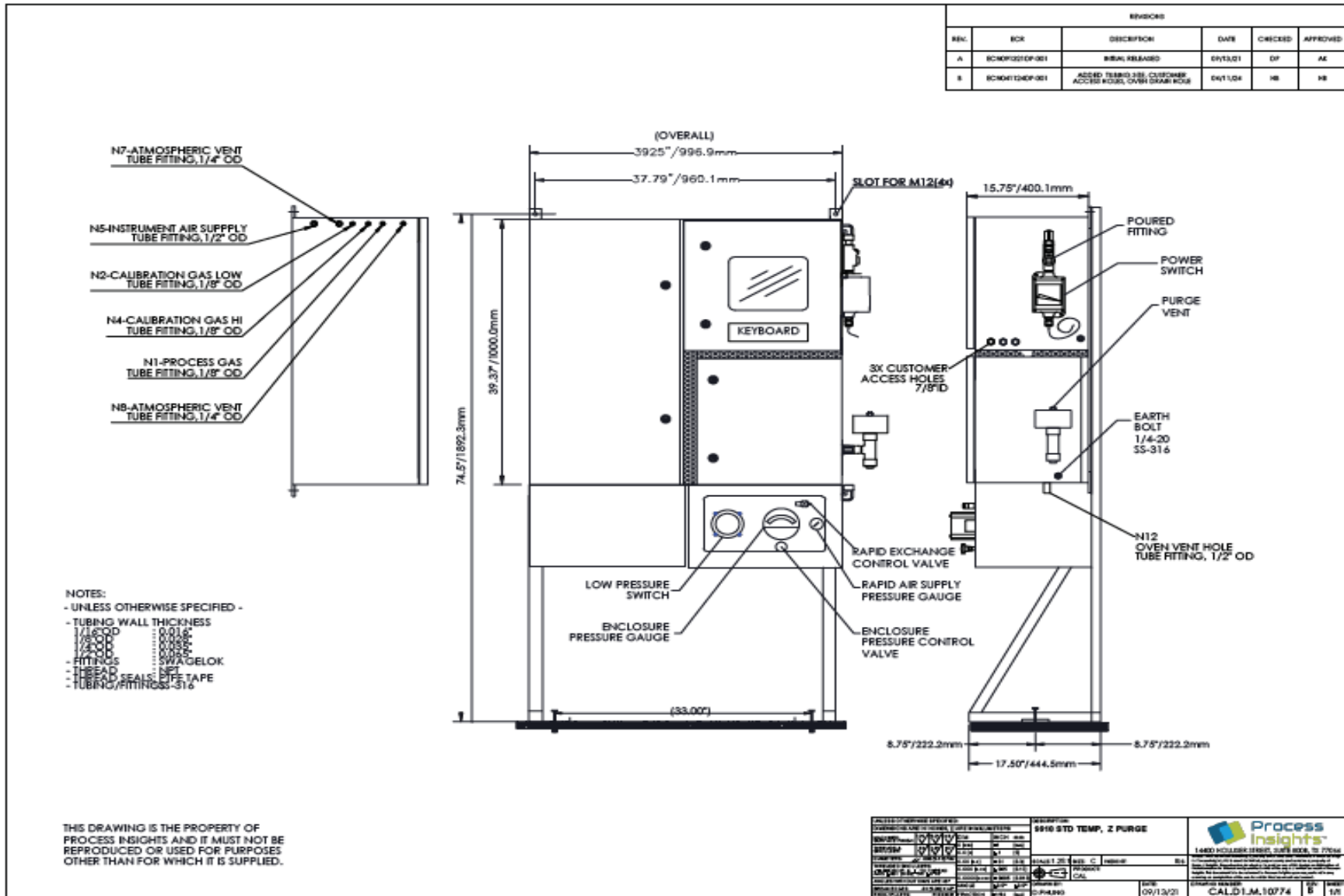

7. ORDERING OF SPARE PARTS

All spare parts may be ordered quoting number and specification from:

PROCESS INSIGHTS CORPORATION

**New York
Manufacturing Offices:**

84G Horseblock Rd.
Yaphank, NY 11980
Tel: 631-345-3434

**Texas Corporate Headquarters,
Sales & Service Offices:**

Building 6, 14400 Hollister Street
Suite 800-B
Houston, TX 77066
Tel: 713-947-9591
Fax: 713-947-7549

E-mail: sales.HOU@Process-Insights.com, support.HOU@Process-Insights.com

Web: <http://www.Process-Insights.com>

**WARNING: Substitution of components may impair hazardous location safety.
La substitution de composants peut nuire à la sécurité des lieux
dangereux.**

All installation and maintenance by trained personnel only.

Please call and reference the below part number for current spare parts pricing.
Immediate pricing is available to all confirmed customers.

7.1 9610CXC™ Standard Temperature Spare Parts List as of 5-2021

SAMPLE CONDITIONING SYSTEM – General Spares

3-5 Year	CAL.98.M.0010	Air Filter Regulator/ Air Regulator
1 Year	CAL.98.M.0241	Replacement Air Filter for Air Reg
3-5 Year	CAL.98.M.0007	Dome Loaded Regulator
3-5 Year	CAL.98.M.0114	Pressure Regulator
3 Year	CAL.98.M.0006	Pressure Gauge, 0-60PSIG, Liquid Fill
5 Year	CAL.98.M.0237	Manifold Block 3-Module
3-5 Year	CAL.98.M.0315	Flow Indicator 10-1000 CCM
3-5 Year	CAL.98.M.0316	Flow Indicator 1-30LPM SS Valve
3-5 Year	CAL.98.M.0008	Flame Arrestor for SCS
5 Year	CAL.98.M.0117	Relief Valve, 0.2-3.5 Bar
5 Year	CAL.18.E.0000	Thermocouple, SCS
5 Year	CAL.98.E.0073	Heater 500 Watt 120V

3-5 Year	CAL.98.M.0009	Tee filter
1 Year	CAL.98.M.0025	Filter Element for Tee Filter
1 Year	XD0.98.M.5023	Coalescing Filters 10/Pack

SPECIFIC GRAVITY CELL

5+ Year	CAL.S4.M.10003	Low Temp Density Cell Assembly c/w Density Cell Converter Board
---------	----------------	--

GAS & AIR ORIFICES

1 Year	CAL.19.M.0017	Orifice Tube 1/8' x 0.10mm
1 Year	CAL.19.M.0013	Orifice Tube 1/8' x 0.15mm
1 Year	CAL.19.M.0004	Orifice Tube 1/8" x 0.20mm
1 Year	CAL.19.M.0018	Orifice Tube 1/8' x 0.25mm
1 Year	CAL.19.M.0005	Orifice Tube 1/8' x 0.30mm
1 Year	CAL.19.M.0006	Orifice Tube 1/4" x 0.55mm
1 Year	CAL.19.M.0007	Orifice Tube 1/4" x 0.60mm
1 Year	CAL.19.M.0008	Orifice Tube 1/4" x 0.65mm
1 Year	CAL.19.M.0009	Orifice Tube 1/4" x 0.70mm
1 Year	CAL.19.M.0010	Orifice Tube 1/4" x 0.75mm
1 Year	CAL.19.M.0012	Orifice Tube 1/4" x 0.80mm
1 Year	CAL.19.M.0011	Orifice Tube 1/4" x 0.85mm
1 Year	CAL.19.M.0014	Orifice Tube 1/4" x 0.90mm
1 Year	CAL.19.M.0015	Orifice Tube 1/4" x 0.95mm
1 Year	CAL.19.M.0016	Orifice Tube 1/4" x 1.00mm

OVEN COMPARTMENT

3-5 Year	CAL.98.M.0018	Oven (60 Volt, Aluminum Housing) – 9600 only
3-5 Year	CAL.98.M.0218	Oven (120 Volt, Stainless Steel Housing)
1 Year	CAL.98.M.0020	THERMOCOUPLE
1 Year	CAL.98.M.0019	Zirconium Oxide Cell
3-5 Year	CAL.98.M.9765	Cell Housing with screens 1/2" vent tube
3-5 Year	CAL.98.M.0030	Cell Housing with screens 1/4" vent tube – 9600 only
5 Year	CAL.18.E.0003	Inner cell connector cable
5 Year	CAL.18.E.0004	Outer cell connector cable
5 Year	CAL.98.M.0343	Flame Arrestor

ELECTRONIC COMPARTMENT

3-5 Year	CAL.98.M.0162	Manifold, Pre-Assembled (Festo)
5 Year	CAL.98.E.0059	Relay Din Mount for digital output alarms
5 Year	CAL.98.E.0075	Relay Din Mount 280VAC,32VDC,10A

5 Year	CAL.98.E.0022	I/O module
5 Year	CAL.98.E.0023	I/O module
5 Year	CAL.70.M.0032	Heater 200 Watt for electronics
5 Year	CAL.10.E.0010	CPU Vortex (required to order CAL.98.E.0097 & CAL98.E.0106 with this CPU)
5 Year	CAL.98.E.0097	Flash Disk Module (required to order CAL.98.E.0106 programming with flash module at no additional charge. Specify program version)
5 Year	CAL.10.E.0000	Analog & Digital I/O board
5 Year	CAL.98.E.0108	LCD Display Mitsubishi
5 Year	CAL.98.E.0071	Surge Protector
5 Year	CAL.98.E.0100	Keyboard NEMA PS2 Interface

POWER SUPPLIES

3-5 Year	CAL.60.E.0033	Vortex Power Supply
3-5 Year	CAL.60.E.0004	Switch Mode Power Supply 24VDC

PUMPS & PUMP ACCESSORIES

3-5 Year	CAL.98.M.0015	Pump Elevated Head
3-5 Year	CAL.98.M.0324	Pump Elevated Head for low pressure models
1 Year	CAL.98.M.0224	Pump Overhaul Kit – TFE

FLOW ALARM OPTION

5 Year	ESS.98.M.0666	Flow Alarm Option
--------	---------------	-------------------

7.2 9610CXC™ Mid Temperature Spare Parts List as of 5-2021

SAMPLE CONDITIONING SYSTEM – General Spares

3-5 Year	CAL.98.M.0010	Air Filter Regulator/ Air Regulator
1 Year	CAL.98.M.0241	Replacement Air Filter for Air Reg
3-5 Year	CAL.98.M.0054	Dome Loaded Regulator
3-5 Year	CAL.98.M.0109	Pressure Regulator Low Pressure Option (used when system is configured for 1 to 5 psig)
3-5 Year	CAL.98.M.0101	Pressure Regulator Standard Pressure Option (used when system is configured for 30 psig)

3 Year	CAL.98.M.0055	Pressure Gauge, 0-60PSIG, mid-temp
5 Year	CAL.98.M.0237	Manifold Block 3-Module
3-5 Year	CAL.98.M.0315	Flow Indicator 10-1000 CCM
3-5 Year	CAL.98.M.0316	Flow Indicator 1-30LPM SS Valve
3-5 Year	CAL.98.M.0008	Flame Arrestor for SCS
5 Year	CAL.98.M.0117	Relief Valve, 0.2-3.5 Bar
5 Year	CAL.18.E.0000	Thermocouple, SCS
5 Year	CAL.98.E.0069	Heater 500 Watt 120V (Mid-Temp)
5 Year	CAL.98.E.0088	Heater 400 Watt 120 V (second heater, used when 2 pumps are used)
3-5 Year	CAL.98.M.0009	Tee filter
1 Year	CAL.98.M.0025	Filter Element for Tee Filter
1 Year	XD0.98.M.5023	Coalescing Filters 10/Pack

SPECIFIC GRAVITY CELL

5+ Year	CAL.S4.M.11982	Mid-Temp Density Cell - Oval c/w Density Cell Converter Board
---------	----------------	--

GAS & AIR ORIFICES

1 Year	CAL.19.M.0017	Orifice Tube 1/8' x 0.10mm
1 Year	CAL.19.M.0013	Orifice Tube 1/8' x 0.15mm
1 Year	CAL.19.M.0004	Orifice Tube 1/8" x 0.20mm
1 Year	CAL.19.M.0018	Orifice Tube 1/8' x 0.25mm
1 Year	CAL.19.M.0005	Orifice Tube 1/8' x 0.30mm
1 Year	CAL.19.M.0006	Orifice Tube 1/4" x 0.55mm
1 Year	CAL.19.M.0007	Orifice Tube 1/4" x 0.60mm
1 Year	CAL.19.M.0008	Orifice Tube 1/4" x 0.65mm
1 Year	CAL.19.M.0009	Orifice Tube 1/4" x 0.70mm
1 Year	CAL.19.M.0010	Orifice Tube 1/4" x 0.75mm
1 Year	CAL.19.M.0012	Orifice Tube 1/4" x 0.80mm
1 Year	CAL.19.M.0011	Orifice Tube 1/4" x 0.85mm
1 Year	CAL.19.M.0014	Orifice Tube 1/4" x 0.90mm
1 Year	CAL.19.M.0015	Orifice Tube 1/4" x 0.95mm
1 Year	CAL.19.M.0016	Orifice Tube 1/4" x 1.00mm

OVEN COMPARTMENT

3-5 Year	CAL.98.M.0018	Oven (60 Volt, Aluminum Housing) – 9600 only
3-5 Year	CAL.98.M.0218	Oven (120 Volt, Stainless Steel Housing)
1 Year	CAL.98.M.0020	THERMOCOUPLE
1 Year	CAL.98.M.0019	Zirconium Oxide Cell

3-5 Year	CAL.98.M.9765	Cell Housing with screens ½” vent tube
3-5 Year	CAL.98.M.0030	Cell Housing with screens 1/4” vent tube – 9600 only
5 Year	CAL.18.E.0003	Inner cell connector cable
5 Year	CAL.18.E.0004	Outer cell connector cable
5 Year	CAL.98.M.0343	Flame Arrestor

ELECTRONIC COMPARTMENT

3-5 Year	CAL.98.M.0162	Manifold, Pre-Assembled (Festo)
5 Year	CAL.98.E.0059	Relay Din Mount for digital output alarms

5 Year	CAL.98.E.0075	Relay Din Mount 280VAC,32VDC,10A
5 Year	CAL.98.E.0022	I/O module
5 Year	CAL.98.E.0023	I/O module

5 Year	CAL.70.M.0032	Heater 200 Watt for electronics
5 Year	CAL.10.E.0010	CPU Vortex (required to order CAL.98.E.0097 & CAL98.E.0106 with this CPU)

5 Year	CAL.98.E.0097	Flash Disk Module (required to order CAL.98.E.0106 programming with flash module at no additional charge. Specify program version)
--------	---------------	--

5 Year	CAL.10.E.0000	Analog & Digital I/O board
5 Year	CAL.98.E.0108	LCD Display Mitsubishi
5 Year	CAL.98.E.0071	Surge Protector
5 Year	CAL.98.E.0100	Keyboard NEMA PS2 Interface

POWER SUPPLIES

3-5 Year	CAL.60.E.0033	Vortex Power Supply
3-5 Year	CAL.60.E.0004	Switch Mode Power Supply 24VDC

PUMPS & PUMP ACCESSORIES

3-5 Year	CAL.98.M.0015	Pump Elevated Head
3-5 Year	CAL.98.M.0324	Pump Elevated Head for low pressure models
1 Year	CAL.98.M.0224	Pump Overhaul Kit – TFE

FLOW ALARM OPTION

5 Year	ESS.98.M.0666	Flow Alarm Option
--------	---------------	-------------------

8. LABELS



cosa+xentaur
84F HORSEBLOCK RD.
YAPHANK, NY 11980
U.S.A.
TEL: 001-631-345-3434



TYPE/MODEL	: COSA 9610 C
HAZARDOUS AREA PROTECTION DEGREE	: CLASS I, DIV2, GROUPS B, C & D
CATEGORY	: TYPE Z - PURGE
CERTIFICATE: FM19CA0067X	: T3C, Ta = +5°C TO +45°C
SERIAL No.	: IP66
POWER SUPPLY	: XXXX
	: 115Vac, 60Hz, 12A /
	: 230Vac, 50Hz, 6A, +/-10%
Um:	: 250 Vrms / Vdc maximum
PURGED ENCLOSURE VOLUME	: 92.5 liter
MINIMUM PRE PURGE VOLUME	: 462.5 liter
MINIMUM PURGE DURATION	: (8 minutes)
MAXIMUM ENCLOSURE LEAKAGE RATE	: 1 liter / second
MINIMUM PURGE SUPPLY PRESSURE	: 4 barG
MINIMUM PRE PURGE FLOW	: 2.8 liter / second
MINIMUM FLOW DURING OPERATION	: 0.5 liter / second
MIN. OVERPRESSURE DURING OPERATION	: 6 mbarG
MAX. OVERPRESSURE DURING OPERATION	: 10 mbarG
MAXIMUM PROCESS GAS FLOW	: 0.8 liter / minute
MAXIMUM PROCESS GAS PRESSURE	: 200 mbarG

Flammable substance oxygen concentration must not exceed 2%.
Flammable substance shall not have a UEL higher than 80%.

WARNING

<ul style="list-style-type: none"> - THIS ENCLOSURE NORMALLY CONTAINS INSTRUMENT AIR AND CAN RELEASE FLAMMABLE SUBSTANCES - DO NOT OPEN THIS CABINET WHEN AN EXPLOSIVE ATMOSPHERE IS PRESENT - DO NOT USE THE OVERRIDE SWITCH WHEN AN EXPLOSIVE ATMOSPHERE IS PRESENT - TO PREVENT THE RISK OF ELECTROSTATIC SPARKING, THE VIEWING PORT SHALL BE CLEANED ONLY WITH A DAMP CLOTH 	<ul style="list-style-type: none"> - CE COFFRET CONTIENT NORMALEMENT INSTRUMENT AIR ET PEUT LIBÉRER DES SUBSTANCES INFLAMMABLES - NE PAS OUVRIR CE CABINET SI UNE EXPLOSIF ATMOSPHÈRE EST PRÉSENT - NE PAS UTILISER LE SWITCH OVERRIDE QUAND UN EXPLOSIF ATMOSPHÈRE EST PRÉSENT - POUR ÉVITER LE RISQUE DE ÉLECTROSTATIQUE ÉTINCELLE, LA VISUALISATION PORT EST NETTOYER UNIQUEMENT AVEC UN CHIFFON HUMIDE
---	--



cosa+xentaur
84F HORSEBLOCK RD.
YAPHANK, NY 11980
U.S.A.
TEL: 001-631-345-3434



TYPE/MODEL	: COSA 9610 US
HAZARDOUS AREA PROTECTION DEGREE	: CLASS I, DIV2, GROUPS: B, C & D.
CATEGORY	: TYPE Z - PURGE,
CERTIFICATE: FM19US0127X	: T3C, Ta = +5°C TO +45°C
SERIAL No.	: IP66
POWER SUPPLY	: XXXX
	: 115Vac, 60Hz, 12A /
	: 230Vac, 50Hz, 6A, +/-10%
Um:	: 250 Vrms / Vdc maximum
PURGED ENCLOSURE VOLUME	: 92.5 liter
MINIMUM PRE PURGE VOLUME	: 462.5 liter
MINIMUM PURGE DURATION	: (8 minutes)
MAXIMUM ENCLOSURE LEAKAGE RATE	: 1 liter / second
MINIMUM PURGE SUPPLY PRESSURE	: 4 barG
MINIMUM PRE PURGE FLOW	: 2.8 liter / second
MINIMUM FLOW DURING OPERATION	: 0.5 liter / second
MIN. OVERPRESSURE DURING OPERATION	: 6 mbarG
MAX. OVERPRESSURE DURING OPERATION	: 10 mbarG
MAXIMUM PROCESS GAS FLOW	: 0.6 liter / minute
MAXIMUM PROCESS GAS PRESSURE	: 200 mbarG

c) a restriction that the flammable substance oxygen concentration must not exceed 2%.
d) a restriction that the flammable substance shall not have a UEL higher than 80%.

WARNING

<ul style="list-style-type: none"> - THIS ENCLOSURE NORMALLY CONTAINS INSTRUMENT AIR AND CAN RELEASE FLAMMABLE SUBSTANCES - DO NOT OPEN THIS CABINET WHEN AN EXPLOSIVE ATMOSPHERE IS PRESENT - DO NOT USE THE OVERRIDE SWITCH WHEN AN EXPLOSIVE ATMOSPHERE IS PRESENT - TO PREVENT THE RISK OF ELECTROSTATIC SPARKING, THE VIEWING PORT SHALL BE CLEANED ONLY WITH A DAMP CLOTH 	<ul style="list-style-type: none"> - THIS ENCLOSURE NORMALLY CONTAINS INSTRUMENT AIR AND CAN RELEASE FLAMMABLE SUBSTANCES - DO NOT OPEN THIS CABINET WHEN AN EXPLOSIVE ATMOSPHERE IS PRESENT - DO NOT USE THE OVERRIDE SWITCH WHEN AN EXPLOSIVE ATMOSPHERE IS PRESENT - TO PREVENT THE RISK OF ELECTROSTATIC SPARKING, THE VIEWING PORT SHALL BE CLEANED ONLY WITH A DAMP CLOTH
---	---



cosa+xentaur
84F HORSEBLOCK RD.
YAPHANK, NY 11980
U.S.A.
TEL: 001-631-345-3434



TYPE/MODEL	: COSA 9610
HAZARDOUS AREA PROTECTION DEGREE	: Ex ib pxb IIC T3 Gb Ta=+5°C to 45°C, IP66.
CATEGORY	: II 2G
CERTIFICATE	: FM11ATEX0006X
SERIAL No.	: XXXX
POWER SUPPLY	: 115Vac, 60Hz, 12A /
	: 230Vac, 50Hz, 6A, +/-10%
Um:	: 250 Vrms / Vdc maximum
PURGED ENCLOSURE VOLUME	: 92.5 liter
MINIMUM PRE PURGE VOLUME	: 462.5 liter
MINIMUM PURGE DURATION	: (8 minutes)
MAXIMUM ENCLOSURE LEAKAGE RATE	: 1 liter / second
MINIMUM PURGE SUPPLY PRESSURE	: 4 barG
MINIMUM PRE PURGE FLOW	: 2.8 liter / second
MINIMUM FLOW DURING OPERATION	: 0.5 liter / second
MIN. OVERPRESSURE DURING OPERATION	: 6 mbarG
MAX. OVERPRESSURE DURING OPERATION	: 10 mbarG
MAXIMUM PROCESS GAS FLOW	: 0.8 liter / minute
MAXIMUM PROCESS GAS PRESSURE	: 200 mbarG

Flammable substance oxygen concentration must not exceed 2%.
Flammable substance shall not have a UEL higher than 80%.

WARNING

<ul style="list-style-type: none"> - THIS ENCLOSURE NORMALLY CONTAINS INSTRUMENT AIR AND CAN RELEASE FLAMMABLE SUBSTANCES - DO NOT OPEN THIS CABINET WHEN AN EXPLOSIVE ATMOSPHERE IS PRESENT - DO NOT USE THE OVERRIDE SWITCH WHEN AN EXPLOSIVE ATMOSPHERE IS PRESENT - TO PREVENT THE RISK OF ELECTROSTATIC SPARKING, THE VIEWING PORT SHALL BE CLEANED ONLY WITH A DAMP CLOTH 	<ul style="list-style-type: none"> - PRESSURIZED ENCLOSURE - THIS ENCLOSURE NORMALLY CONTAINS INSTRUMENT AIR AND CAN RELEASE FLAMMABLE SUBSTANCES - DO NOT OPEN THIS CABINET WHEN AN EXPLOSIVE ATMOSPHERE IS PRESENT - DO NOT USE THE OVERRIDE SWITCH WHEN AN EXPLOSIVE ATMOSPHERE IS PRESENT - TO PREVENT THE RISK OF ELECTROSTATIC SPARKING, THE EXTERIOR OF THE EQUIPMENT SHALL BE CLEANED ONLY WITH A DAMP CLOTH.
---	--



cosa+xentaur
84F HORSEBLOCK RD.
YAPHANK, NY 11980
U.S.A.
TEL: 001-631-345-3434

TYPE/MODEL	: WIM 9610
HAZARDOUS AREA PROTECTION DEGREE	: Ex ib pxb IIC T3 Gb Ta=+5°C to 45°C, IP66
CERTIFICATE	: IECEx FMG 13.0037X
SERIAL No.	: XXXX
POWER SUPPLY	: 115Vac, 60Hz, 12A /
	: 230Vac, 50Hz, 6A, +/-10%
Um:	: 250 Vrms / Vdc maximum
PURGED ENCLOSURE VOLUME	: 92.5 liter
MINIMUM PRE PURGE VOLUME	: 462.5 liter
MINIMUM PURGE DURATION	: (8 minutes)
MAXIMUM ENCLOSURE LEAKAGE RATE	: 1 liter / second
MINIMUM PURGE SUPPLY PRESSURE	: 20 PSIG
MINIMUM PRE PURGE FLOW	: 120 PSIG
MINIMUM FLOW DURING OPERATION	: 2.8 liter / second
MIN. OVERPRESSURE DURING OPERATION	: 0.5 liter / second
MAX. OVERPRESSURE DURING OPERATION	: 6 mbarG
MAX. OVERPRESSURE DURING OPERATION	: 10 mbarG
MAXIMUM PROCESS GAS FLOW	: 0.8 liter / minute
MAXIMUM PROCESS GAS PRESSURE	: 200 mbarG

Flammable substance oxygen concentration must not exceed 2%.
Flammable substance shall not have a UEL higher than 80%.

WARNING

<ul style="list-style-type: none"> - PRESSURIZED ENCLOSURE - THIS ENCLOSURE NORMALLY CONTAINS INSTRUMENT AIR AND CAN RELEASE FLAMMABLE SUBSTANCES - DO NOT OPEN THIS CABINET WHEN AN EXPLOSIVE ATMOSPHERE IS PRESENT - DO NOT USE THE OVERRIDE SWITCH WHEN AN EXPLOSIVE ATMOSPHERE IS PRESENT - TO PREVENT THE RISK OF ELECTROSTATIC SPARKING, THE EXTERIOR OF THE EQUIPMENT SHALL BE CLEANED ONLY WITH A DAMP CLOTH. 	<ul style="list-style-type: none"> - PRESSURIZED ENCLOSURE - THIS ENCLOSURE NORMALLY CONTAINS INSTRUMENT AIR AND CAN RELEASE FLAMMABLE SUBSTANCES - DO NOT OPEN THIS CABINET WHEN AN EXPLOSIVE ATMOSPHERE IS PRESENT - DO NOT USE THE OVERRIDE SWITCH WHEN AN EXPLOSIVE ATMOSPHERE IS PRESENT - TO PREVENT THE RISK OF ELECTROSTATIC SPARKING, THE EXTERIOR OF THE EQUIPMENT SHALL BE CLEANED ONLY WITH A DAMP CLOTH.
--	--